

**DOUBLE FOOT SWITCHES
WITH EN 418
EMERGENCY STOP**

DESCRIPTION	CONTACTS	CODE	MIN. PACK	WEIGHT
Foot switch with trigger mechanism requiring positive action to allow pedal operation. Colour: ■ PANTONE 102C	Slow break		Quantity	gr.
	1NO + 1NO	IP7018EM	1	5.300
	2NO + 2NO	IP7019EM	1	5.300

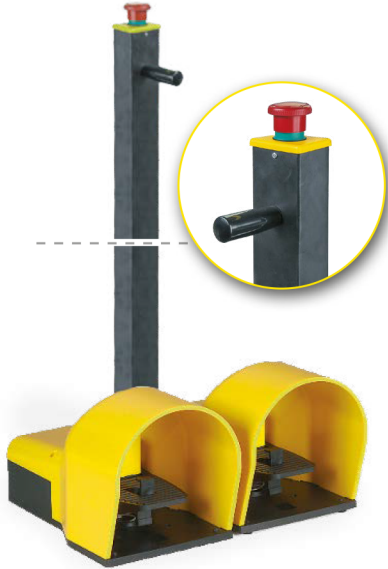

ON REQUEST

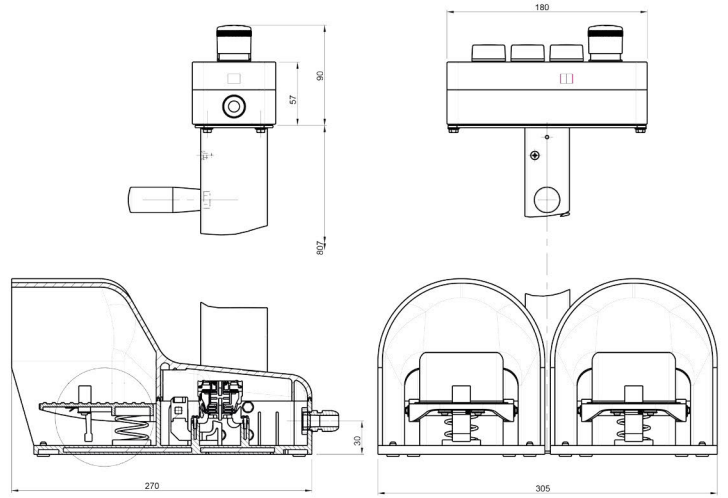

Available double foot switch IP7027 with PQ04 station 4 holes with EN ISO 13850 emergency stop.

Double foot switches thermoplastic type with EN ISO 13850.

DOUBLE FOOT SWITCHES

DESCRIPTION	CONTACTS	CODE	MIN. PACK	WEIGHT
Foot switch with trigger mechanism requiring positive action to allow pedal operation. Colour: ■ PANTONE 102C	Slow break		Quantity	gr.
	1NO + 1NO	IP7018	1	3.100
	2NO + 2NO	IP7019	1	3.100



DIMENSIONAL DRAWINGS

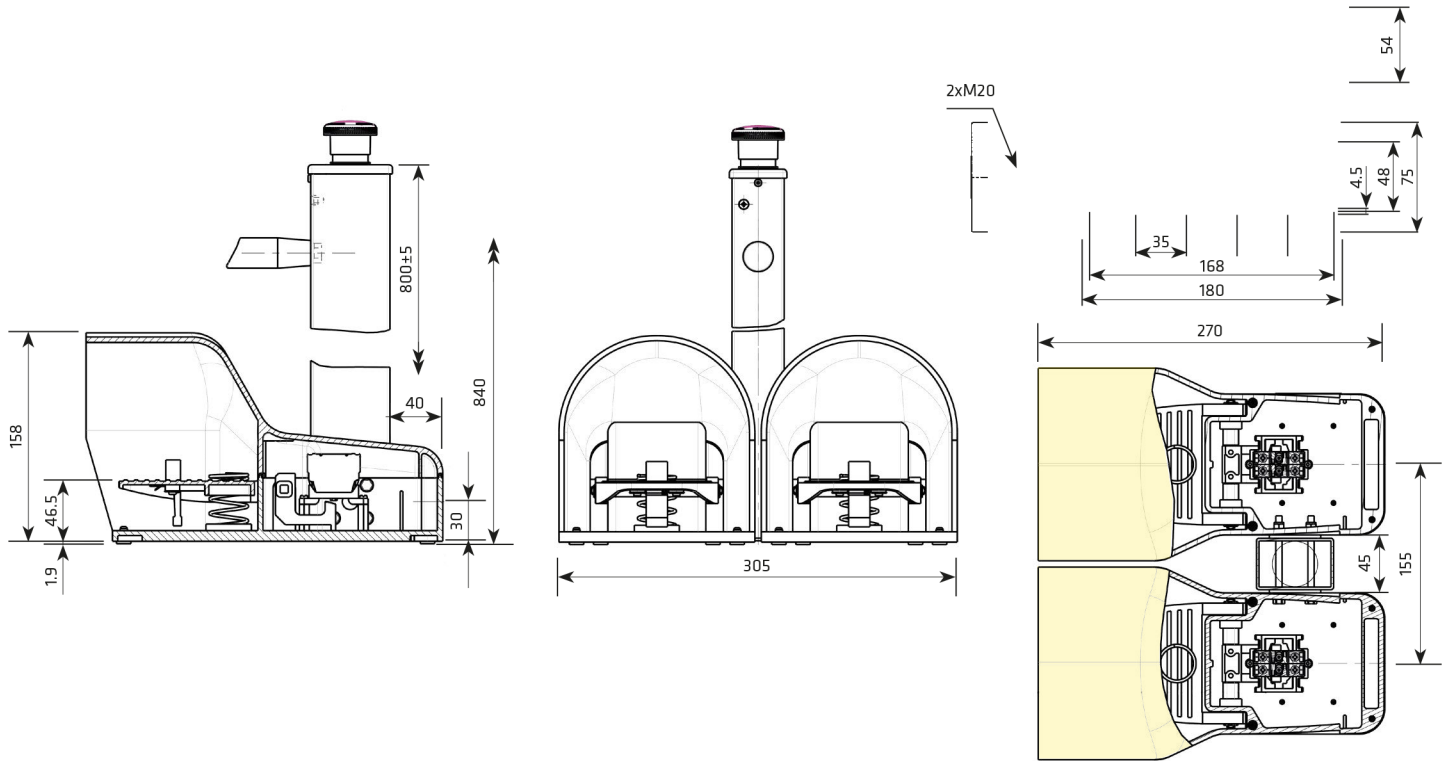

IP54 □

DIMENSIONAL DRAWINGS

