

On-Off Cam Switches, Type B, Panel Mounting



COMPLY WITH RULES

IEC 947-3, EN 60947-3, UL508

SERIES		P012-P016-P020 PX12-PX16-PX20			C025-C032-C040 CX25-CX32-CX40			C063-C080		G125		G200	
Protection class	control terminals	EN 60529 (UL50) NEMA 4X			IP65 (Type 1 - 4 -4X) IP40			IP65 (Type 1 - 4 -4X) IP40		IP65 IP40		IP65 -	
	control with knob only				IP20 (P0) - IP10 (PX)			IP20 (P0) - IP10 (PX)		IP00		IP00	
Material group		EN 60947-1			II			II		II		IIIA	
Pollution grade		EN 60947-1			3			3		3		3	
Flammability		UL94			VO (Live Electrical parts)			VO (Live Electrical parts)		VO (Live Electrical parts)		VO (Live Electrical parts)	
Ambient temperature		°C			Operating: -40 +85			Operating: -40 +85		Operating: -40 +70		Operating: -15 +55	
		°C			Storage: -40 +70			Storage: -40 +70		Storage: -40 +70		Storage: -25 +70	
Climate Withstand		IEC 68 part 2-3			Hot damp			Hot damp		Hot damp		-	
		IEC 68 part 2-30			Unsettled hot damp			Unsettled hot damp		Unsettled hot damp		-	
Terminal screw identification		EN50013			EN50013			EN50013		EN50013		-	
Connections	Terminal block caliber	EN60947-1			A3			A5		A7		-	
	Terminal screw				M3,5			M4		2xM4		Hex. screw M8 for bars and cable lugs	
	Screwing torque	EN60947-1			0,8 Nm (7,2 lb. in.)			1,2 Nm (10,6 lb. in.)		1,2 Nm (10,6 lb. in.)		-	
		UL508			7,5 lb. in. (0,85 Nm)			12 lb. in. (1,4 Nm)		10,62 lb. in. (1,2 Nm)		-	
Connectable section	Flexible conductors min/max	mm ²			1x0,75/4 - 2x0,75/2,5			2x2,5/10		2,5/35		-	
		AWG			10 - 18			14 - 6		14 - 3		-	
	Solid conductors min/max	mm ²			1x0,75/4 - 2x0,75/2,5			2x2,5/10		2,5/35		-	
		AWG			10 - 18			14 - 6		14 - 3		-	
Contacts		Double breaking			Double breaking			Double breaking		Double breaking		Double breaking	
Opening angles		30° - 45° - 60° - 90°			30° - 45° - 60° - 90°			45° - 60° - 90°		60° - 90°		60° - 90°	
Mechanical lifetime at 120 operations for hour	mil./cl	1	1	1	1	1	1	1	1	0,1	0,1	0,1	0,1
Electrical lifetime at 120 operations for hour	mil./cl	1	0,75	0,75	1	0,75	0,75	0,5	0,25	0,01	0,01	0,01	0,01
CERTIFICATIONS		P012 PX12	P016 PX16	P020 PX20	C025 CX25	C032 CX32	C040 CX40	C063	C080	G125		G200	
CE	CE mark - Europe	■	■	■	■	■	■	■	■	■		■	
cULus	cUL Listed - USA and Canada	●	●	●	●	●	●	●	●	●		●	
IMQ	IMQ Istituto Marchio Qualità - Italy	●	●	●	●	●	●	●	●	●		●	
CCC	CCC Cina	●	●	●	●	●	●	●	●	●		●	
EAC	EAC Russia	●	●	●	●	●	●	●	●	●		●	

■ Comply to the requirements by passed test. ● Approved.

EN 60947-3 CHARACTERISTICS			PO12 - PX12	PO16 - PX16	PO20 - PX20	CO25 - CX25	CO32 - CX32	CO40 - CX40	CO63	CO80	G125	G200
Rated operating voltage Ue	V		690	690	690	690	690	690	690	690	690	690
Rated insulation voltage Ui	V		690	690	690	690	690	690	690	690	690	690
Rated impulse withstand voltage Uimp (sectionable)	kV		4	4	4	6	6	6	8	8	6	6
Rated thermal current Ith	A		16	20	25	32	40	50	85	100	150	225
Rated thermal current in enclosed Ithe	A		12	16	20	25	32	40	85	100	150	225
Frequency	Hz		50/60	50/60	50/60	50/60	50/60	50/60	50/60	50/60	50/60	50/60
RATED OPERATING CURRENT Ie: alternate current			PO12 - PX12	PO16 - PX16	PO20 - PX20	CO25 - CX25	CO32 - CX32	CO40 - CX40	CO63	CO80	G125	G200
AC-21A Switching resistive loads with light overloads	690V	A	12	16	20	25	32	40	63	80	125	200
AC-22A Switching mixed resistive and inductive loads at light overloads	690V	A	12	16	20	25	32	40	63	80	125	200
AC-23A Periodic switching of motors	single phase - 1 pole	110V A/kW	12/1,1	14/1,5	18/2	25/1,5	30/2,2	35/3	45/4	63/5,5	-	-
		230V A/kW	12/2,2	14/3	18/4	25/4	30/5,5	35/6,5	45/7,5	63/11	-	-
		230V A/kW	10/3	14/4	16/5	25/7,5	30/9	35/11	50/15	58/18,5	140/45	169/55
		400V A/kW	10/5,5	14/7,5	16/9	22/11	24/15	32/18,5	40/22	54/30	78/45 (415V)	95/55 (415V)
		500V A/kW	10/7,5	14/10	16/11	22/11	27/18,5	32/22	40/30	54/37	65/45	79/55
AC3 Starting of cage motors (Interruption hile running)	single phase - 2 poles	110V A/kW	10/0,75	12/1,1	16/1,5	22/1,1	25/1,5	30/2,5	36/3,7	45/4	-	-
		230V A/kW	10/2	12/2,2	16/3,5	22/3,7	25/4	30/5,5	36/6,5	45/7,5	-	-
		230V A/kW	8/2,2	10/3	12/4	18/5,5	23/7,5	27/9	37/11	47/15	115/37	140/45
		400V A/kW	8/4	10/5	12/6	18/7,5	23/11	27/15	35/18,5	44/22	64/37 (415V)	78/45 (415V)
		500V A/kW	8/5,5	10/7,5	12/8	18/11	23/15	27/18,5	35/22	44/30	53/37	64/45
Nominal interruption power AC-23A (cosφ 0,45)		230V A	80	104	128	200	240	280	400	464	-	-
		400V A	80	104	128	176	216	256	320	432	-	-
		500V A	80	112	128	176	216	256	320	432	-	-
		690V A	80	112	128	160	176	200	256	320	-	-
Power dissipation for each pole	W	0,3*	0,35*	0,4*	-	-	-	-	-	-	-	
RATED OPERATING CURRENT Ie: direct current			PO12 - PX12	PO16 - PX16	PO20 - PX20	CO25 - CX25	CO32 - CX32	CO40 - CX40	CO63	CO80	G125	G200
DC-21A Switching resistive loads with light overloads	50V (1 phase)	A	10	12	16	20 ▼	25 ▼	32 ▼	-	-	-	-
DC-22A Switching mixed resistive and inductive loads at light overloads	30V (1 phase)	A	8	10	12	16 ▼	20 ▼	25 ▼	-	-	-	-
SHORT CIRCUIT CHARACTERISTICS			PO12 - PX12	PO16 - PX16	PO20 - PX20	CO25 - CX25	CO32 - CX32	CO40 - CX40	CO63	CO80	G125	G200
Rated short-time short circuit withstand current Icw (1 s)	A		300	300	300	500	500	500	1200	1200	-	-
Rated short circuit making capacity Icm	A		1200	1200	1200	2840	2840	2840	2000	2000	-	-
Conditional rated short circuit withstand current	kA		5	5	5	10	10	10	10	10	20	20
Fuse rating gG	690V	A	20	20	20	40 ■	40 ■	40 ■	100	100	125 ▲	200 ▲
UL 508 CHARACTERISTICS			PO12 - PX12	PO16 - PX16	PO20 - PX20	CO25 - CX25	CO32 - CX32	CO40 - CX40	CO63	CO80	G125	G200
General Use	600V AC	A	12	16	20	25	32	40	63	85	125	175
Standard motor load	single phase - 2 poles	120V AC HP (FLA)	0,5 (9,8)	1 (16)	1,5 (20)	1,5 (20)	2 (24)	3 (34)	5 (56)	5 (56)	-	-
		240V AC HP (FLA)	1 (8)	1,5 (10)	2 (12)	3 (17)	5 (28)	5 (28)	7,5 (40)	10 (50)	-	-
	3 phases - 3 poles	200V AC HP (FLA)	1,5 (6,9)	3 (11,04)	5 (17,5)	7,5 (25,3)	7,5 (25,3)	10 (32,2)	-	-	10 (56)	15 (84)
		240V AC HP (FLA)	3 (9,6)	5 (15,2)	5 (15,2)	7,5 (22)	7,5 (22)	10 (28)	15 (42)	20 (54)	20 (54)	25 (68)
		480V AC HP (FLA)	5 (7,6)	7,5 (11)	10 (14)	15 (21)	20 (27)	20 (27)	30 (40)	40 (52)	40 (52)	50 (65)
		600V AC HP (FLA)	5 (6,1)	7,5 (9)	10 (11)	15 (17)	20 (22)	20 (22)	40 (41)	50 (52)	50 (52)	50 (52)

▼ Values not reported on the IMQ files. ■ Fuses type gG 40a 500V ▲ Fuses type gG/Gm

| RANGE AC21A | 12A - 16A - 20A |

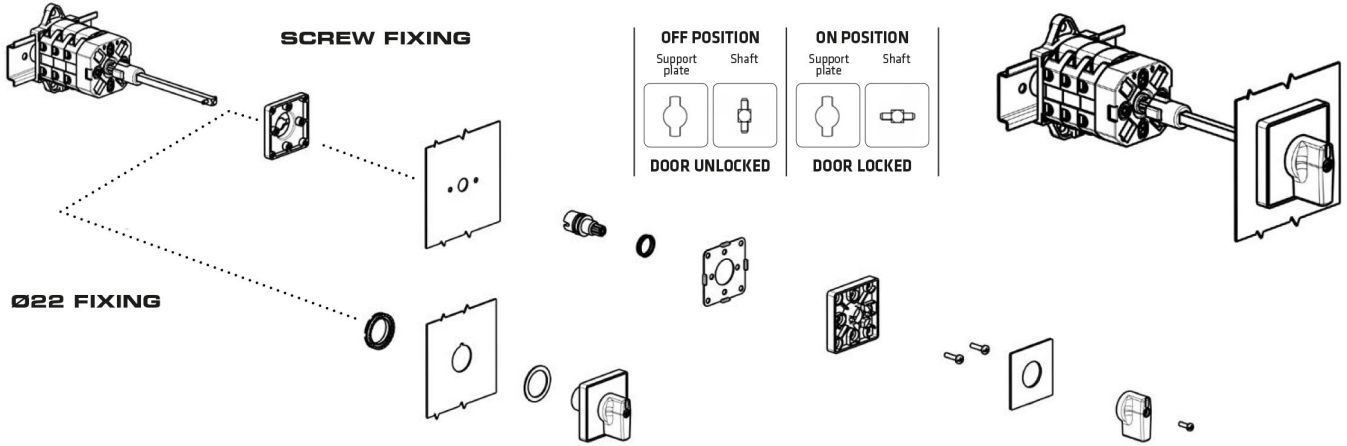

| RANGE AC21A | 25A - 32A - 40A |

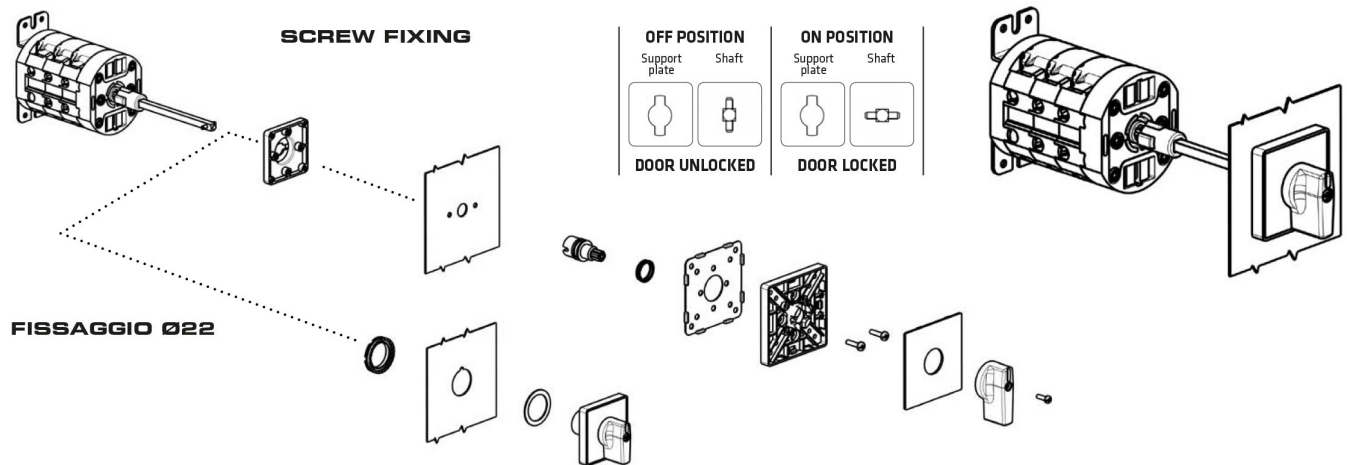

| RANGE AC21A | 63A - 80A |

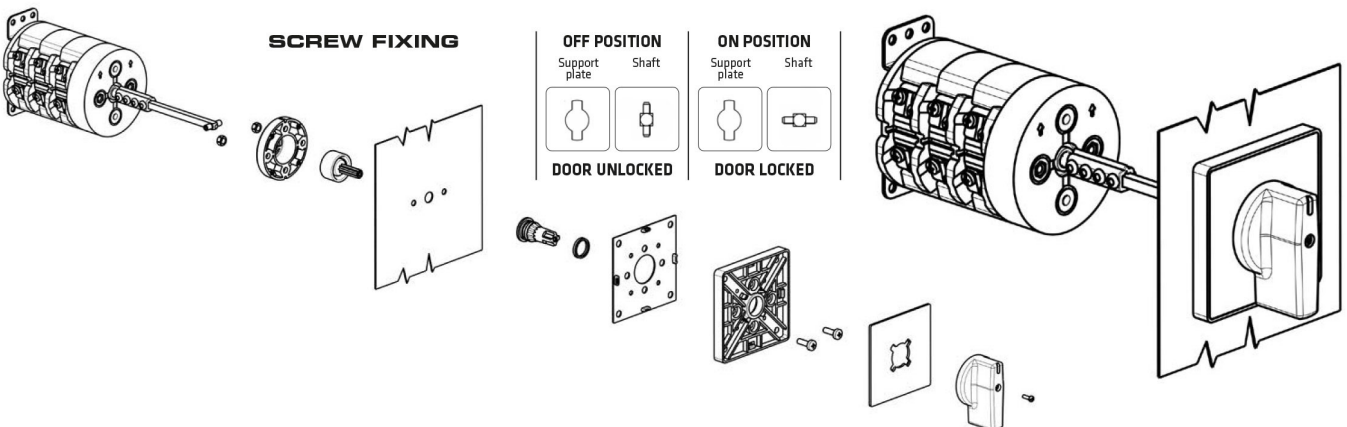



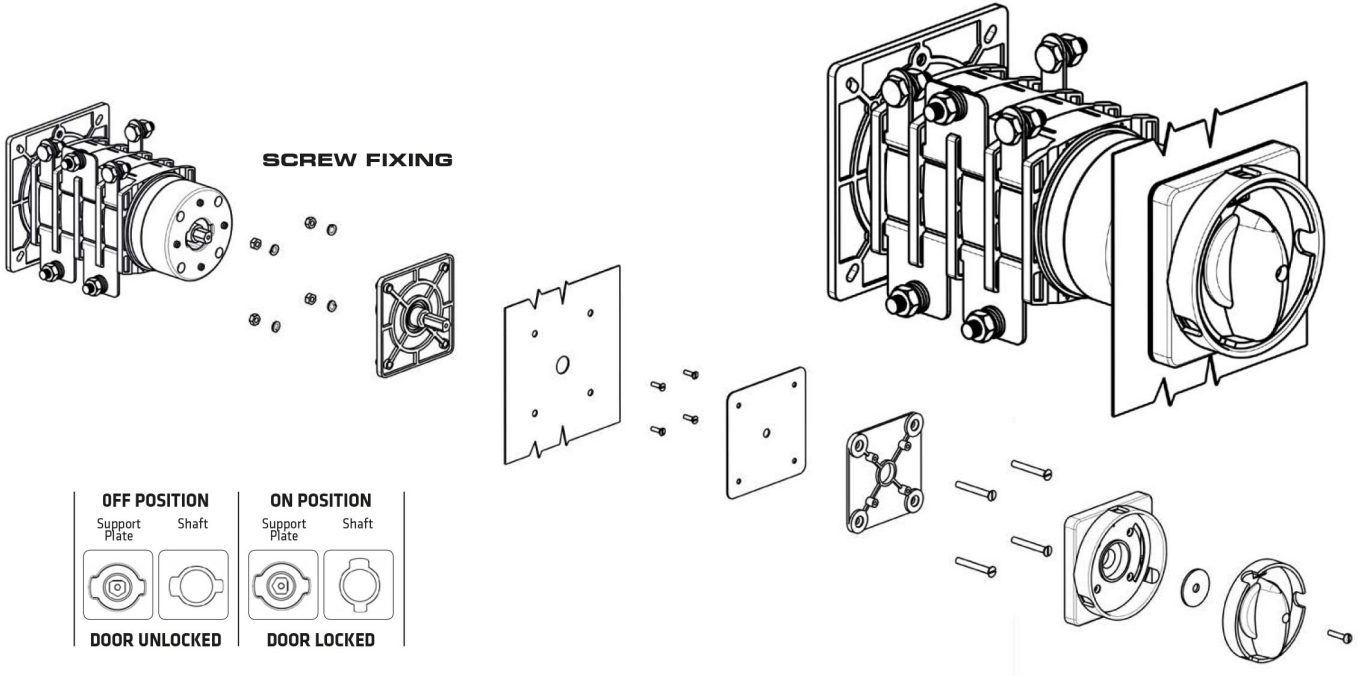



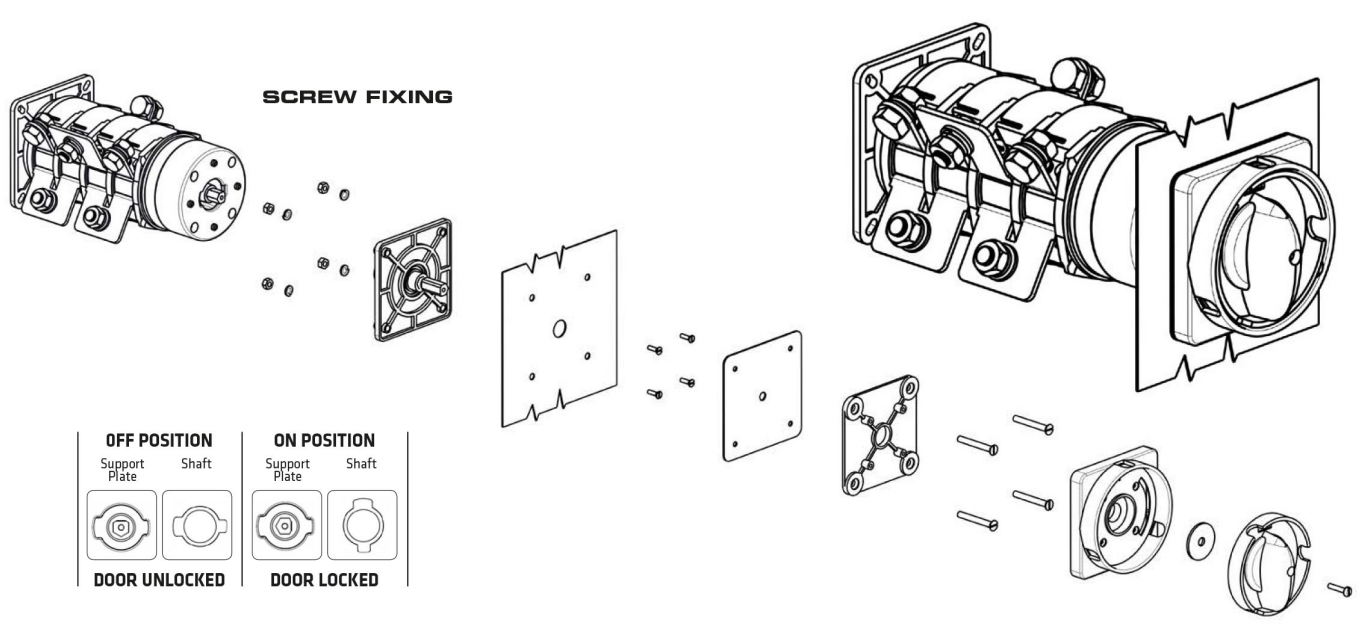





| RANGE AC21A | 125A |







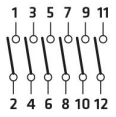









| RANGE AC21A | 200A |



On-Off Cam Switches, Type B, Panel Mounting

	12-16-20A	 90°	 90°	 90°	 90°																																																																												
	25-32-40A																																																																																
	63-80A	 1 3 2 4	 1 3 5 2 4 6	 1 3 5 7 2 4 6 8	 1 3 5 7 9 11 2 4 6 8 10 12																																																																												
	125A																																																																																
	200A	<table border="1" data-bbox="440 1220 578 1293"> <tr><td>1</td><td>3-4</td><td></td><td>X</td></tr> <tr><td></td><td>1-2</td><td></td><td>X</td></tr> <tr><td>WAF</td><td>CONT.</td><td>0</td><td>1</td></tr> </table>	1	3-4		X		1-2		X	WAF	CONT.	0	1	<table border="1" data-bbox="724 1167 862 1293"> <tr><td>2</td><td>5-6</td><td></td><td>X</td></tr> <tr><td></td><td>3-4</td><td></td><td>X</td></tr> <tr><td>1</td><td>1-2</td><td></td><td>X</td></tr> <tr><td>WAF</td><td>CONT.</td><td>0</td><td>1</td></tr> </table>	2	5-6		X		3-4		X	1	1-2		X	WAF	CONT.	0	1	<table border="1" data-bbox="1008 1167 1146 1293"> <tr><td>2</td><td>7-8</td><td></td><td>X</td></tr> <tr><td></td><td>5-6</td><td></td><td>X</td></tr> <tr><td></td><td>3-4</td><td></td><td>X</td></tr> <tr><td>1</td><td>1-2</td><td></td><td>X</td></tr> <tr><td>WAF</td><td>CONT.</td><td>0</td><td>1</td></tr> </table>	2	7-8		X		5-6		X		3-4		X	1	1-2		X	WAF	CONT.	0	1	<table border="1" data-bbox="1292 1125 1430 1293"> <tr><td>3</td><td>11-12</td><td></td><td>X</td></tr> <tr><td></td><td>9-10</td><td></td><td>X</td></tr> <tr><td>2</td><td>7-8</td><td></td><td>X</td></tr> <tr><td></td><td>5-6</td><td></td><td>X</td></tr> <tr><td>1</td><td>3-4</td><td></td><td>X</td></tr> <tr><td></td><td>1-2</td><td></td><td>X</td></tr> <tr><td>WAF</td><td>CONT.</td><td>0</td><td>1</td></tr> </table>	3	11-12		X		9-10		X	2	7-8		X		5-6		X	1	3-4		X		1-2		X	WAF	CONT.	0	1
1	3-4		X																																																																														
	1-2		X																																																																														
WAF	CONT.	0	1																																																																														
2	5-6		X																																																																														
	3-4		X																																																																														
1	1-2		X																																																																														
WAF	CONT.	0	1																																																																														
2	7-8		X																																																																														
	5-6		X																																																																														
	3-4		X																																																																														
1	1-2		X																																																																														
WAF	CONT.	0	1																																																																														
3	11-12		X																																																																														
	9-10		X																																																																														
2	7-8		X																																																																														
	5-6		X																																																																														
1	3-4		X																																																																														
	1-2		X																																																																														
WAF	CONT.	0	1																																																																														
SERIES	AC21A	2 POLES	3 POLES	4 POLES	6 POLES																																																																												
P012	12A	P0120002B	P0120003B	P0120004B	P0120006B																																																																												
P016	16A	P0160002B	P0160003B	P0160004B	P0160006B																																																																												
P020	20A	P0200002B	P0200003B	P0200004B	P0200006B																																																																												
C025	25A	C0250002B	C0250003B	C0250004B	C0250006B																																																																												
C032	32A	C0320002B	C0320003B	C0320004B	C0320006B																																																																												
C040	40A	C0400002B	C0400003B	C0400004B	C0400006B																																																																												
C063	63A	C0630002B	C0630003B	C0630004B	C0630006B																																																																												
C080	80A	C0800002B	C0800003B	C0800004B	C0800006B																																																																												
G125	125A	G1250002B	G1250003B	G1250004B	G1250006B																																																																												
G200	200A	G2000002B	G2000003B	G2000004B	G2000006B																																																																												

ACTUATOR	FIXING	PO12 - PO16 - PO20		CO25 - CO32 - CO40		CO63 - CO80		G125	G200
		 90°	 90°	 90°	 90°	 90°	 90°	 90°	 90°
	screw	020/0001	-	021/0001	-	220/0001	-	-	-
	ø22	095/0001	-	095/0001	-	-	-	-	-
	screw	030/0001	-	-	-	-	-	-	-
	ø22	070/0001	-	070/0001	-	-	-	-	-
	screw	005/0001	-	005/0001	-	-	-	-	-
	ø22	077/0001	-	077/0001	-	-	-	-	-
	screw	006/0001	-	006/0001	-	-	-	-	-
	ø22	069/0001	-	069/0001	-	-	-	-	-
	screw	011/0001	011/0001-A	011/0001	011/0001-A	211/0001	211/0001-1	451/0001	451/0001
	ø22	063/0001	063/0001-1	063/0001	063/0001-1	-	-	-	-
	screw	012/0001	012/0001-2	012/0001	012/0001-2	212/0001	212/0001-1	452/0001	452/0001
	ø22	064/0001	064/0001-1	064/0001	064/0001-1	-	-	-	-
DOORLOCK SHAFT		Metallic □5x85mm				Metallic □6x100mm		Direct doorlock coupling (no metallic shaft)	



All base mounting's actuators are equipped with doorlock function that permits to open the door only in "0" position.

▲ UL50 NEMA Type 1-4-4X

▲ Metallic shaft can be cut according customer needs. Longer metallic shaft are available.



12-16-20A

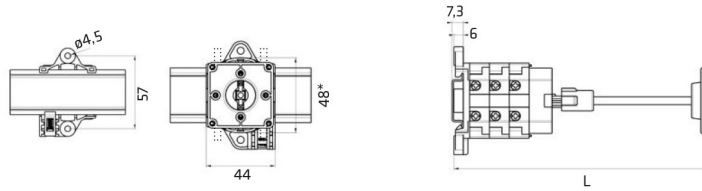

WAFER GAP	L x WAFER N°						
	1	2	3	4	5	6	
12,7	min*	80,4	93,1	105,8	118,5	131,2	143,9
	max	138,4	151,1	163,8	176,5	189,2	201,9

* Minimum lenght with cut shaft.

* If cam switch is provided of external bridge (wafer to wafer) the height will be increased of ~ 2 mm for the lower and upper sides.



25-32-40A

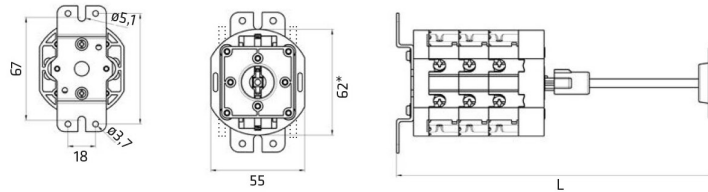

WAFER GAP	L x WAFER N°						
	1	2	3	4	5	6	
17,5	min*	96	113,5	131	148,5	166	183,5
	max	154	171,5	189	206,5	224	241,5

* Minimum lenght with cut shaft.

* If cam switch is provided of external bridge (wafer to wafer) the height will be increased of ~ 1 mm for the lower and upper sides.



63-80A

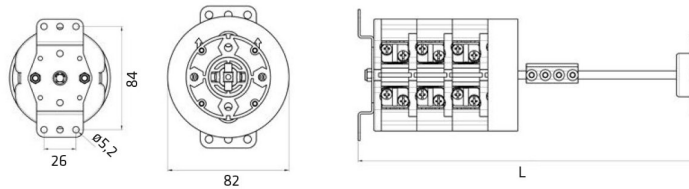

WAFER GAP	L x WAFER N°						
	1	2	3	4	5	6	
26	min*	148	174	200	226	252	278
	max	196	222	248	274	300	376

* Minimum lenght with cut shaft.



125A

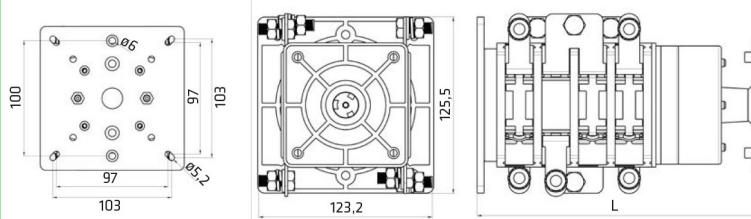

WAFER GAP	L x WAFER N°						
	1	2	3	4	5	6	
26	min*	125	151	177	203	229	255

* Direct doorlock coupling bloccoporta (no metallic shaft).



200A

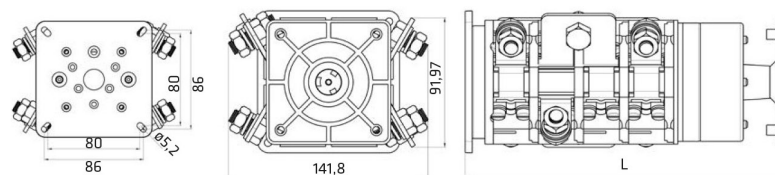

WAFER GAP	L x WAFER N°						
	1	2	3	4	5	6	
32	min*	131	163	195	227	259	291

* Direct doorlock coupling bloccoporta (no metallic shaft).

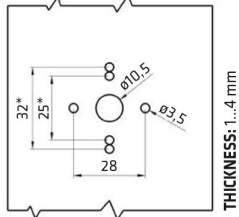

THICKNESS: 1...4 mm

FIXING:
 Captive M3 bolt - 28 mm
 * ALTERNATIVE FIXING
 Screwplast 25 or 32 mm

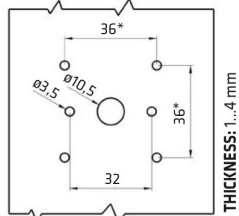
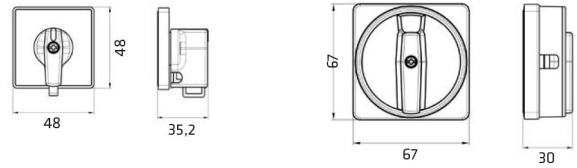
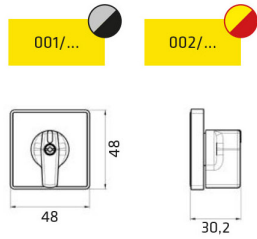

THICKNESS: 1...4 mm

FIXING:
 Captive M3 bolt - 32 mm
 * ALTERNATIVE FIXING
 Screwplast □36 mm

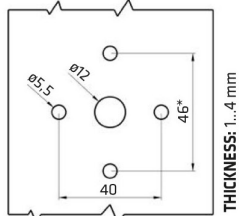
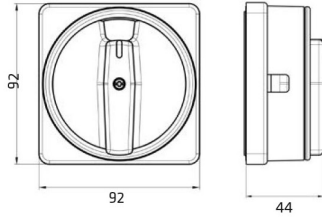
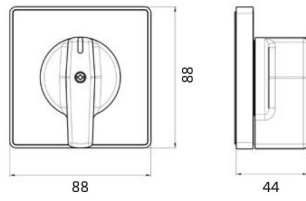
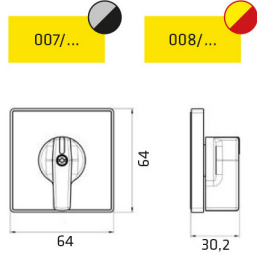

THICKNESS: 1...4 mm

FIXING:
 Captive M5 bolt - 40 mm
 * ALTERNATIVE FIXING
 M5 - 46 mm

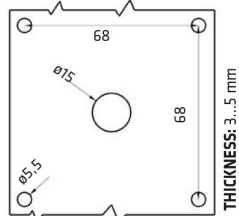
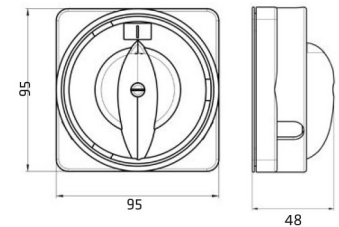
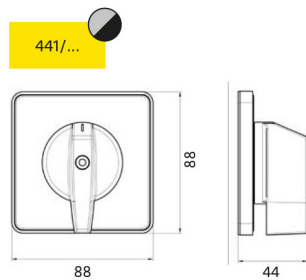

THICKNESS: 3...5 mm

FISSAGGIO:
 M5 bolt □68 mm

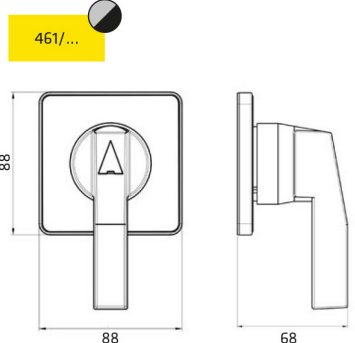



12-1B-20A

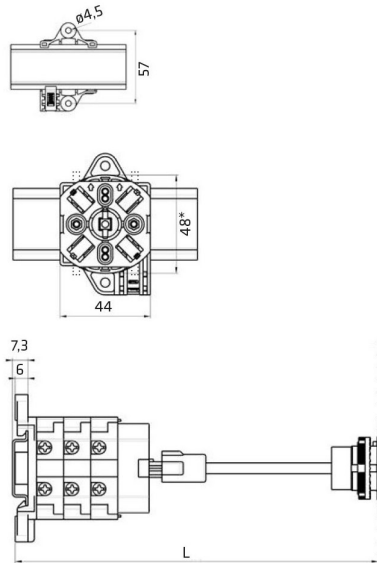

WAFER GAP	PANEL THICKNESS	L x WAFER N°						
		1	2	3	4	5	6	
12,7	1 mm	min*	84,2	96,9	109,6	122,3	135	147,7
		max	143,7	156,4	169,1	181,8	194,5	207,2
	2 mm	min*	83,2	95,9	108,6	121,3	134	146,7
		max	142,7	155,4	168,1	180,8	193,5	206,2
	3 mm	min*	82,2	94,9	107,6	120,3	133	145,7
		max	141,7	154,4	167,1	179,8	192,5	205,2
	4 mm	min*	81,2	93,9	106,6	119,3	132	144,7
		max	140,7	153,4	166,1	178,8	191,5	204,2
	5 mm	min*	80,2	92,9	105,6	118,3	131	143,7
		max	139,7	152,4	165,1	177,8	190,5	203,2
	6 mm	min*	78,2	91,9	104,6	117,3	130	142,7
		max	138,7	151,4	164,1	176,8	189,5	202,2

* Minimum length with cut shaft.

* If cam switch is provided of external bridge (wafer to wafer) the height will be increased of ~ 2 mm for the lower and upper sides.



25-3B-40A

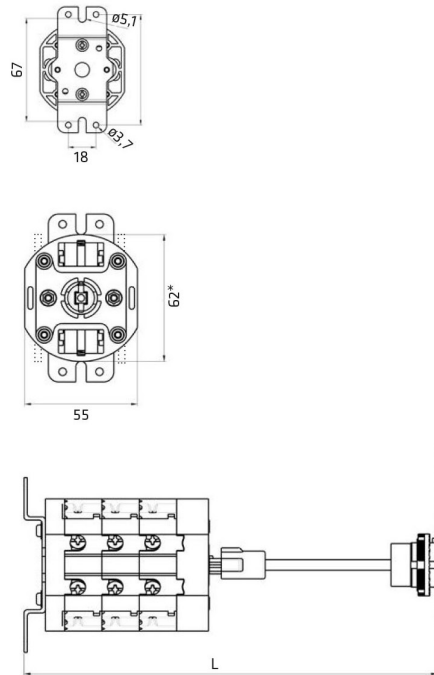

WAFER GAP	PANEL THICKNESS	L x WAFER N°						
		1	2	3	4	5	6	
17,5	1 mm	min*	93,8	115,8	133,3	150,8	168,3	185,8
		max	157,8	175,3	192,8	210,3	227,8	245,3
	2 mm	min*	97,3	114,8	132,3	149,8	167,3	184,8
		max	156,8	174,3	191,8	209,3	226,8	244,3
	3 mm	min*	96,3	113,8	131,3	148,8	166,3	183,8
		max	155,8	173,3	190,8	208,3	225,8	243,3
	4 mm	min*	95,3	112,8	130,3	147,8	165,3	182,8
		max	154,8	172,3	189,8	207,3	224,8	242,3
	5 mm	min*	94,3	111,8	129,3	146,8	164,3	181,8
		max	153,8	171,8	188,8	206,3	223,8	241,3
	6 mm	min*	93,3	110,8	128,3	145,8	163,3	180,8
		max	152,8	170,3	187,8	205,3	222,8	240,3

* Minimum length with cut shaft.

* If cam switch is provided of external bridge (wafer to wafer) the height will be increased of ~ 1 mm for the lower and upper sides.

