



**CEMBRE**

THERMAL TRANSFER PRINTER

**MG4 MG4A MG4E**

CE

UK  
CA



**M  
G4**



ENGLISH

OPERATION AND MAINTENANCE MANUAL  
(translation of the original instruction)

## 1.1 Description

The **Markingenius MG4** is an industrial labelling printer designed to offer a very high quality and long-lasting printing for text, logos, electrical symbols, QR codes and all kinds of vector images. It is equipped with a ribbon save system, a useful function that allows you to consume only the ribbon needed for printing.

Its reliability and robustness mean that the MG4 can be used intensively, making it suitable for all kinds of applications. The large on-board touch screen enables quick and easy management of print projects.

All CEMBRE MG products print using Windows True Type fonts in black or colour, at very high speed. It is also possible to reproduce Clipart images, drawings, barcodes and bitmap images, including in very small sizes. Each monochrome ribbon can print more than 300,000 MG-TPMF 4x10 mm tags with full printable surface coverage, while printing times, costs and ribbon life may be further improved due to the ribbon optimisation system, depending on the type of material being printed. As the pigment deposited from the ribbon dries instantaneously, printed sheets are immediately ready to use.

Projects can be set up and created from a PC with the GENIUSPRO software for managing production orders or, if necessary, via the GENIUSPRO MOBILE APP developed by CEMBRE for IOS and Android devices (smartphones and tablets) for the latest changes on site, on the electrical panel or on the edge of the machine.

### Geniuspro Mobile APP

Projects can be set up and created from a PC with the GENIUSPRO software for managing production orders or, if necessary, via the GENIUSPRO MOBILE APP developed by CEMBRE for IOS and Android devices (smartphones and tablets) for the latest changes on site, on the electrical panel or on the edge of the machine.

To download the app on Android devices:

- Open the Google Play Store app.
- Search for and select **Geniuspro Mobile**.
- Select INSTALL.
- Follow the on-screen instructions to complete the transaction and download the content.

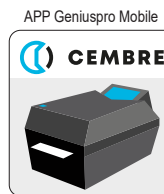

To download the app on Apple devices:

- Open the App Store app.
- Search for and select **Geniuspro Mobile**.
- Select GO.
- Follow the on-screen instructions to complete the transaction and download the content.

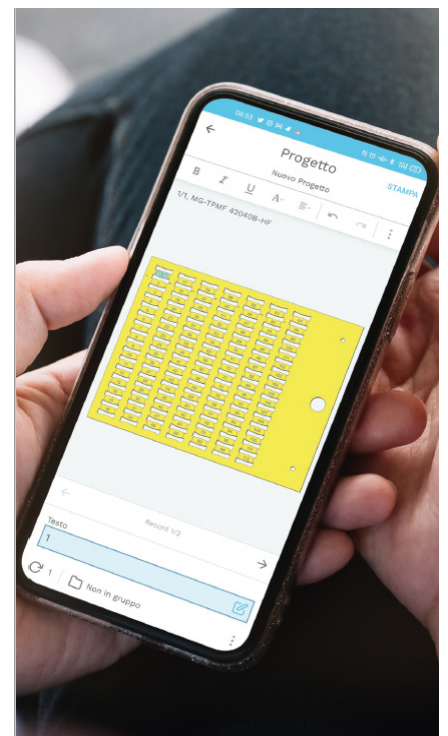

## 1.2 Technical specifications

Printer	type	MG4	MG4A	MG4E
Printing mode		thermal transfer		
Supply voltage	V $\approx$	24		
Current	A	3,75		
Printing speed (one sheet)	Sek.	9		
Maximum resolution	DPI	300 x 600		
Maximum printable surface	mm	140 x 110		
Operating temperature	°C (°F)	da + 15 a + 35 (from + 59 to + 95)		
Relative humidity (without condensation)	%	from 30 to 80		
Dimensions (length x width x height)	mm (inch)	409 x 236 x 240 (16.1 x 9.3 x 9.4)		
Weight	kg (lbs)	6,1 (13.4)		
Acoustic noise (UNI EN ISO 11202)		L <sub>pA</sub> < 70 dB L <sub>pCPeak</sub> < 130 dB		
Minimum system requirements to use the "GENIUSPRO" software		PC with Intel® Core™ i3 processor, equivalent or higher 4 Gb of RAM memory 2 Gb of available hard disk space, monitor resolution 1280x1024 operating system: Windows® 7, Windows® 8, Windows® 10 32/64 bit		
Interfaces (connectivity)	type	Ethernet 10 / 100 Base-T Wi-Fi WLAN 802.11b/g/n 2.4 GHz USB 2.0 Hi-Speed		
Interface templates	type	MG2-PLT 991002 MG2-QTB 991011 MG2-PWC 991000	MG2-PLT 991002 MG2-QTB 991011 MG2-PTM 991010	MG2-PLT 991002 MG2-QTB 991011 MG2-PTD 991007
Print ribbon (øe x øi x width)		28 x 53 x 120		
<b>Wi-Fi module</b>				
Frequency band	GHz	2,400 - 2,483		
Maximum output power	mW	100		
<b>Power supply</b>				
Power	W	90		
Input: Supply voltage	V~	100 - 240		
Frequency	Hz	50 / 60		
Current	A	0,6 (230 V) - 1,3 (115 V)		
Output: Voltage	V $\approx$	24		
Current	A	3,75 max.		
Weight	kg	0,45		
<b>Power cord</b>				
	type	EU	USA/CAN	UK

Trademarks: Windows 7®, 8® and 10® are registered trademarks of Microsoft Corporation.

## 1 Introduction

### 1.3 Warnings

In this documentation, important information and warnings are marked as follows:

**Danger!**

Indicates a hazard for the operator caused by electrical voltage.

**Caution!**

Indicates possible damage to property or a loss of quality.

**Note!**

Tips to facilitate operation or indicate important operating steps.

### 1.4 Intended Use

- This device has been produced according to the current state-of-the-art and commonly recognised safety rules and technical standards. Nevertheless, risks to the physical safety and life of the user or third parties, as well as damage to the device and other property, cannot be completely ruled out during its use.
- The device may only be used in perfect technical condition, in accordance with its intended purpose, with full awareness of safety warnings and hazards and in compliance with the instructions.
- The device is intended exclusively for printing on suitable materials approved by the manufacturer. Any different or excessive use is considered improper. The manufacturer/supplier is not liable for damage resulting from improper use; the risk is the sole responsibility of the user.
- The concept of proper use also includes compliance with the instructions, including the manufacturer's recommendations/maintenance standards.

### 1.5 Safety Warnings

The device is designed to be powered via:

- power supply unit included in the supply, to be connected to mains with voltage from 100 V to 240 V, 50 / 60 Hz.
- 18 V CEMBRE rechargeable battery (accessory on request).
- Only use the code 6971120 power supply unit included in the supply. In case of failure or replacement please contact CEMBRE.
- Turn off all affected devices (computers, printers, accessories) before disconnecting cables.
- The device may only be used in a dry environment and in the absence of any moisture (water spray, fog, etc.).
- Do not use the device in a potentially explosive atmosphere.
- Do not use the device near high voltage lines.
- The device or its parts can become hot during printing.
- Do not touch the printer during operation and wait for it to cool before changing material or disassembly.
- Only carry out the actions described in these operating instructions.  
Further work may only be carried out by trained personnel or service technicians.
- Incorrect intervention on electronic units and their software can cause faults.
- Other incorrect procedures or modifications to the device may also compromise safe operation.
- Technical servicing must always be carried out by qualified personnel with the necessary technical knowledge and tools to carry out the required work.

### 1.6 Unpacking and installing the device

- ▶ Remove the contents from the box.
- ▶ Check that the printer has not been damaged in transit.
- ▶ Check that all package contents are present.
- ▶ Place the printer on a flat surface.

**Package contents** (Fig. 1)

- A** – MG4 Plug & Play basic printer
- B** – USB cable
- C** – Power cable
- D** – Power supply unit GST90A24-P1M code 6971120
- E** – "FD-GENIUSPRO" USB key containing the "GENIUSPRO" software (including the licences that can be activated in the reserved area at [www.cembre.com](http://www.cembre.com)) and user manual
- F** – MG2-PLT 991002 interface template for marking tags, labels, nameplates and FLAT series products.
- G** – MG2-QTB 991011 interface template for MG-CPM-01, -02, -03, -04, -07, -11 type terminal block markers
- H** – MG2-PWC 991000 interface template for printing type MG-TPM type tags for holders
- I** – MG2-PTM 991010 interface template for printing type MG-TDM, MG-TDMO type cable tags
- L** – MG2-PTD 991007 interface template for printing type MG-TDM type 6 stems cable tags
- M** – MG2-ETR 991600 black print ribbond
- N** – MG2-CRB 991654 ribbon take-up spool cardboard core

**Accessories on request:**

- O** – ASC55-EU ..... Battery charger 220-240 V / 50-60 Hz with EU plug
- ASC55-UK ..... Battery charger 220-240 V / 50-60 Hz with UK plug
- ASC55-USA/CA ..... Battery charger 115 V / 60 Hz with USA plug
- ASC55-AUS/NZ ..... Battery charger 220-240 V / 50-60 Hz 85 with AUS plug
- P** – CB1820L ..... Rechargeable battery 18V - 2,0 Ah Li-Ion
- CB1852L ..... Rechargeable battery 18V - 5.2 Ah Li-Ion



**Note!**  
Keep the original packaging for subsequent transport.



**Caution!**  
Water and moisture damage the device and print materials.  
The label printer should only be installed in dry locations and protected from water splashes.

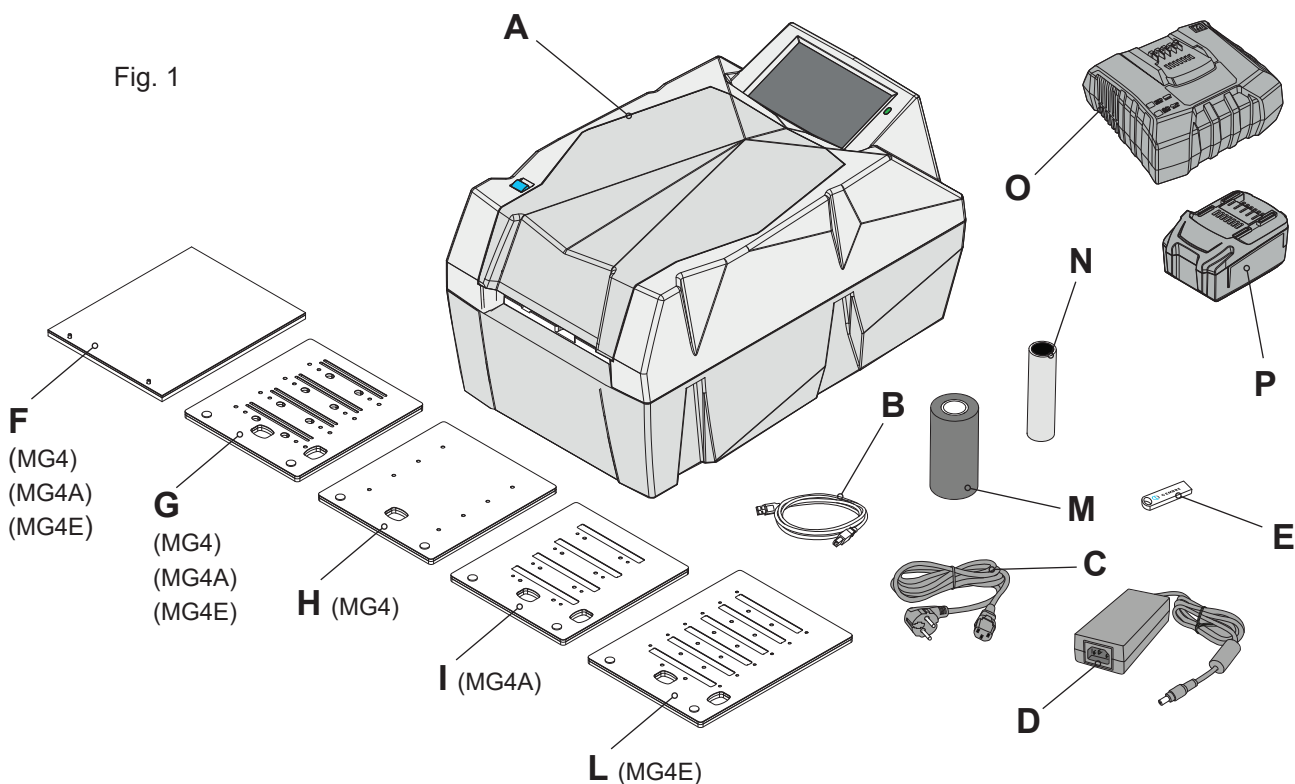

## 2.1 Device overview

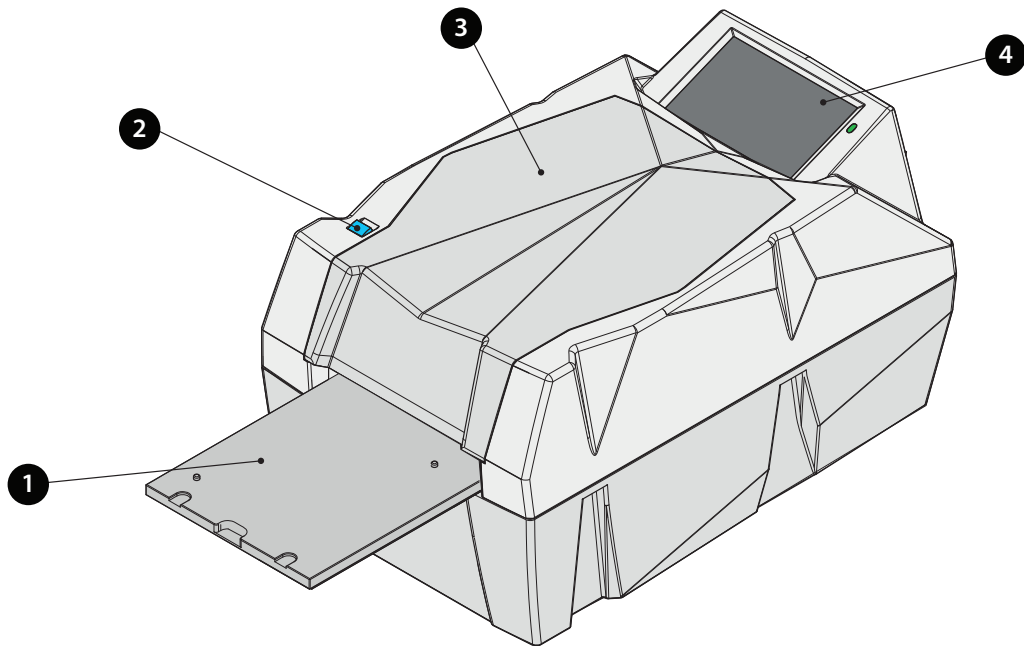

Fig. 2a

- 1 Mobile carriage
- 2 Button to open/close sheet loading carriage.
- 3 Upper lid
- 4 Five inch LCD touch screen display
- 5 Battery contact protection lid
- 6 Battery release button
- 7 ON/OFF switch
- 8 10/100 Base-T ethernet port
- 9 Type A USB socket
- 10 Type B USB socket
- 11 Power supply connection socket

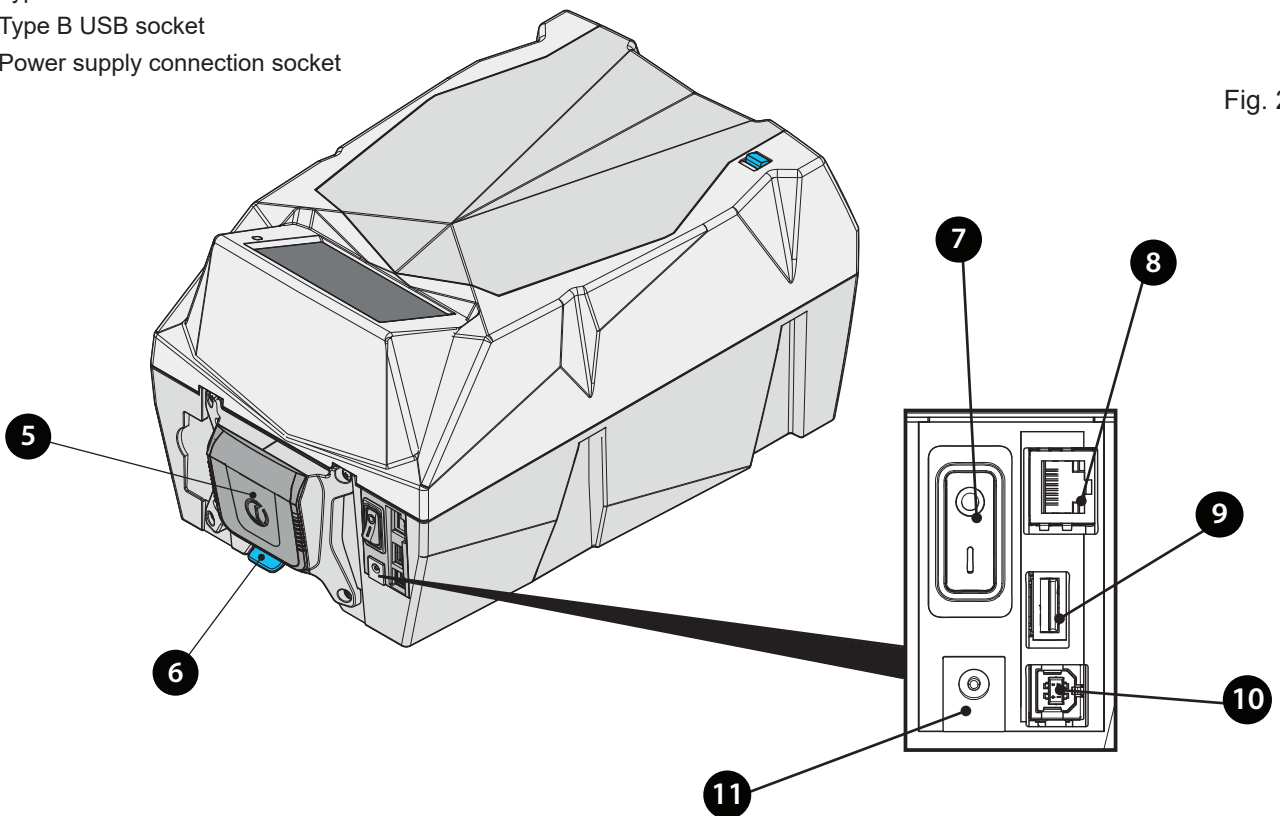

Fig. 2b

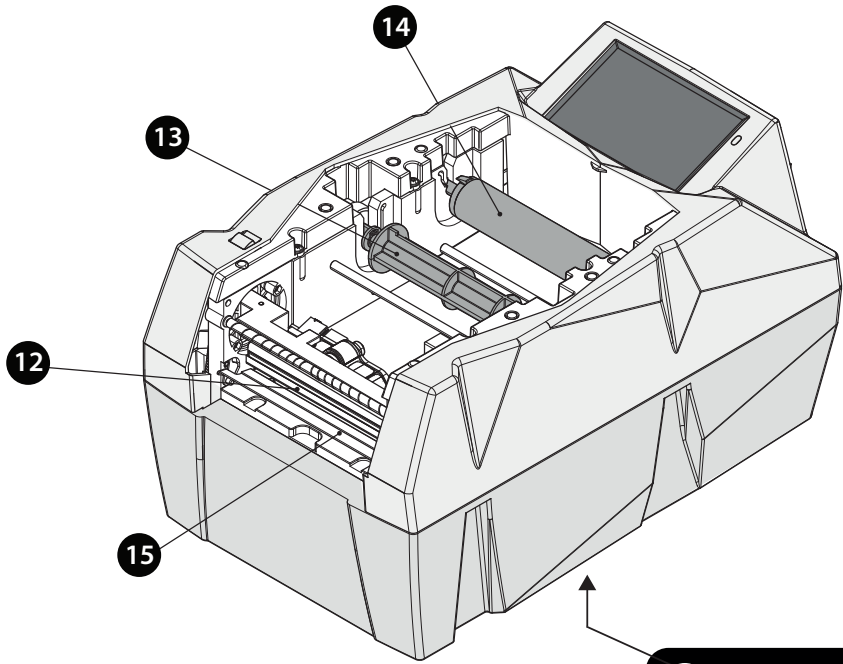

Fig. 2c

- 12 Print head
- 13 Ribbon take-up spool
- 14 Ribbon feed spool
- 15 Media guide
- 16 Data label

Via Serenissima, 9  
Brescia - Italy

MODEL: <b>MG4</b>	24 V $\approx$ 3.75 A
M S/N: _____	
YEAR: _____	

This device complies with Part 15 of the FCC Rules. Operation is subject to the following two conditions:  
 (1) This device may not cause harmful interference, and  
 (2) This device must accept any interference received, including interference that may cause undesired operation.  
 Changes or modification not expressly approved by the party responsible for compliance could void the user's authority to operate the equipment.

Contains FCC ID: Z84-WL188BMOD  
 Contains IC: 451-WL188BMOD  
 Contains transmitter module with certificate number: 201-135370  
T021818A

made in Italy

### 2.1.1 Overall dimensions (mm)

Fig. 3

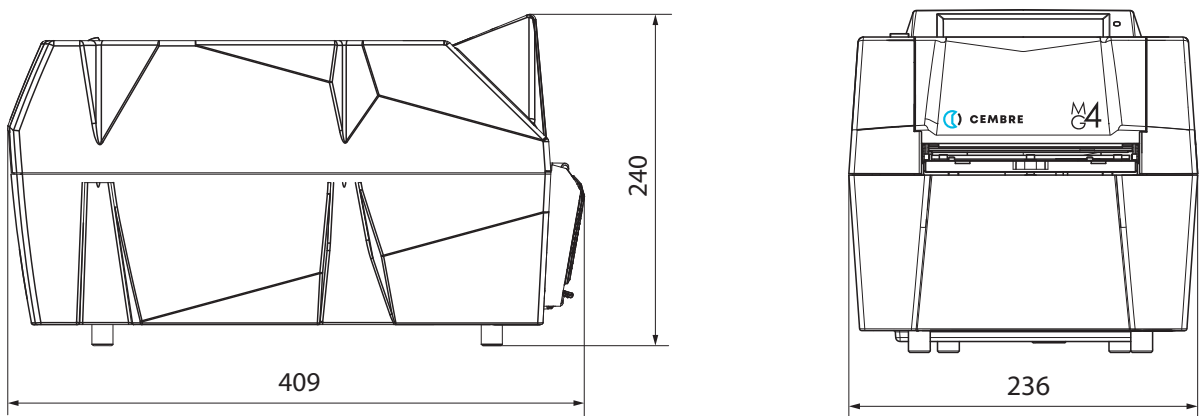

## 2.2 Connecting the device

The standard interfaces and connections are described in § 2.1.

### 2.2.1 Mains power supply and switching on

The printer is equipped with a broad spectrum power supply unit. Operation with a mains voltage of 230 V / 50 Hz or 115 V / 60 Hz is possible without any modification to the device.

- ▶ Make sure that the printer is switched off before connecting, switch (7) in position 0 (Fig. 5).
- ▶ Connect the power supply unit connector (D) to port (11) on the back of the printer.
- ▶ Connect the power cable to the connector (20) of the power supply unit and to an electrical outlet.
- ▶ Press the switch (7) so it is at position I to turn on the printer, after a short test cycle the initial screen will appear on the display (refer to § 3.1).



**Only connect the power supply unit to electrical outlets with protective earth contact.  
The electrical outlet must be located near the printer and always be easily accessible when needed.**

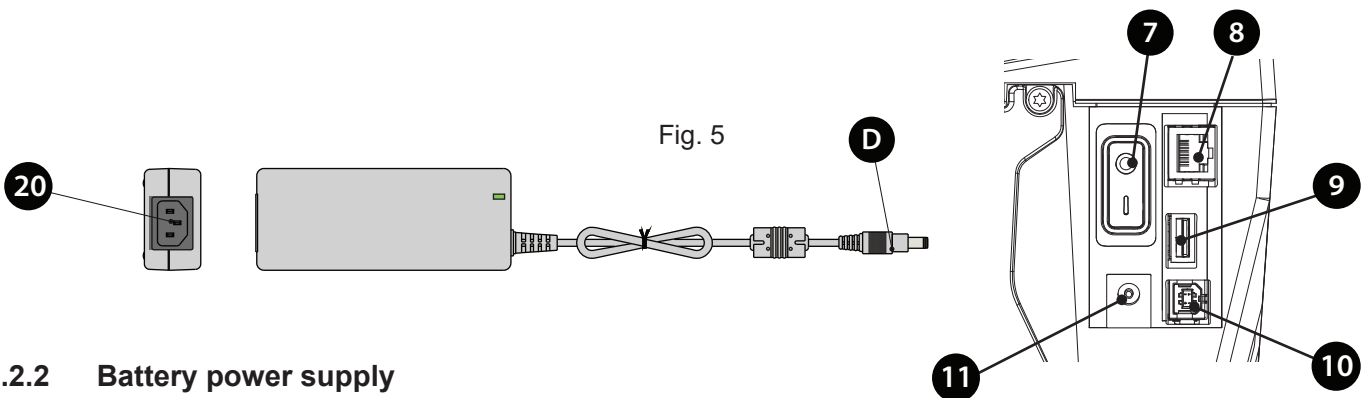

### 2.2.2 Battery power supply

The printer can also be powered by a separate battery without being connected to the mains (see § 7).

### 2.2.3 Direct connection to a computer

- ▶ Connect the USB cable from the computer to the connector (10) on the back of the printer and then proceed with the installation. The printer will be automatically installed and visible in the Control Panel, Devices and Printers of the PC.

### 2.2.4 Connection via Ethernet network

- ▶ Connect the cable from the network to the Ethernet port (8) on the back of the printer.
- ▶ From the MG4 display, select: Setting > Network > LAN settings.
- ▶ Click on EDIT button (Enable DHCP if you want to use this automatic IP address assignment protocol, if DHCP is not used, disable it and manually enter the IP address).

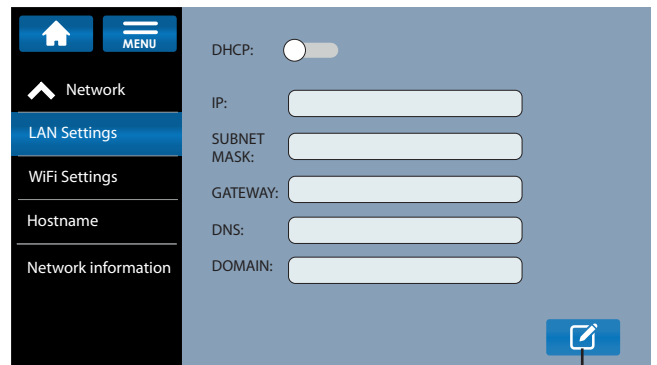

EDIT

- #### 2.2.4.1
- ▶ Add the printer as a TCP/IP device on the PC, setting the IP address shown on the MG4 display, or the hostname (default = MG4-[printer serial number] e.g. MG4-20AA001).
  - ▶ Select CEMBRE S.P.A. in the Manufacturer column and then the MG4 driver in the Printer column. Click "Next" to complete the installation.



### 2.2.5 Connection via Ethernet network

- ▶ From the MG4 display, select: Settings ▷ Network ▷ WiFi settings.
- ▶ Click on the edit button and select DHCP.
- ▶ Search for a select the desired Wi-Fi network and enter its password.
- ▶ Proceed as described in § 2.2.4.1.

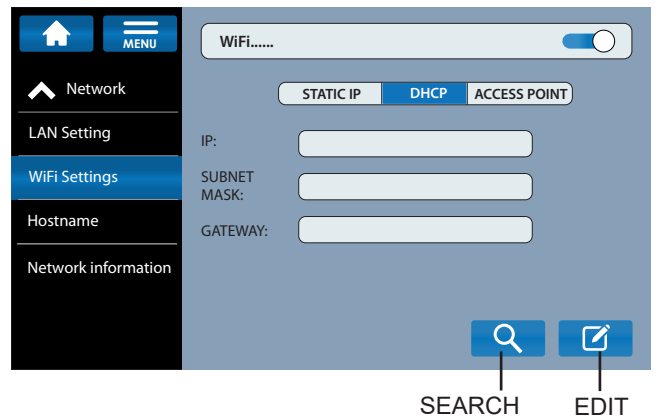

### 2.2.6 Connection via an Access Point AP

- ▶ From the MG4 display, select: Network ▷ Settings ▷ WiFi settings
- ▶ Activate the button in the top right-hand corner
- ▶ Click on the edit button and select ACCESS DHCP.
- ▶ Select the SSID network generated by the MG4, enter the password, or, in "Network Information", scan the QR code.  
If necessary, configure a dedicated channel.
- ▶ Proceed as described in § 2.2.4.1.

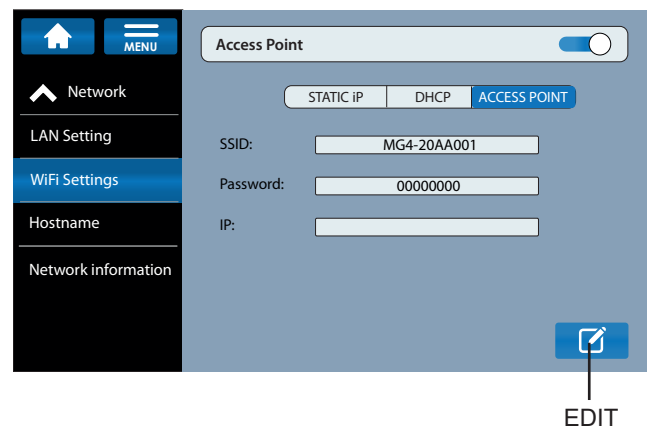

### 2.2.7 Installing the "GENIUSPRO" operating software

- ▶ The USB flash drive (FD-GENIUSPRO) contains the "GENIUSPRO" operating software and the drivers necessary for the printer to function. Any updates to the "GENIUSPRO" software can be downloaded from the website [www.cembre.com](http://www.cembre.com).
- ▶ Insert the USB drive into the computer's USB port and proceed with the installation of "GENIUSPRO" through the SETUP file.

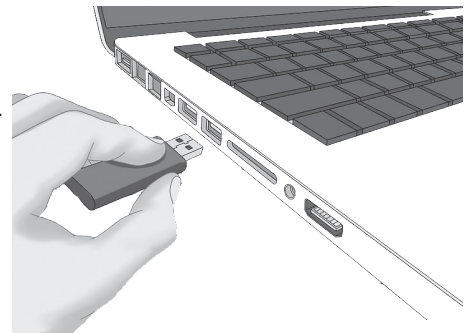

### 2.2.8 Connection to the "Geniuspro Mobile" app

- ▶ Install the "Geniuspro Mobile" app on your Android or iOS mobile device (refer to § 1.1).
- ▶ Pair the MG4 to the app via an access point (proceed as described in section 2.2.6) or via a WiFi network (proceed as described in § 2.2.5 verifying that the device is also connected to the WiFi network already connected to the MG4).
- ▶ Open the "Geniuspro Mobile" app, click on ▷ ADD PRINTERS.
- ▶ Enter in the "Network Information" menu of the MG4 and scan the QRcode on the display via the mobile device, pairing the MG4.



## 10 3 Touch screen display

The user can control the operation of the printer with the touch screen display, for example:

- Manage the print queue, stop, continue or cancel jobs.
- Set printing parameters, perform diagnostics of main functions and configure the interface, language and time.

The settings made on the touch screen display are used for the basic configuration of the printer.

The print settings are already configured for correct use and are protected by the **security PIN: 0000**

### 3.1 Home screen



#### Note!

In case of standby (black screen), touch the screen to restore operation.

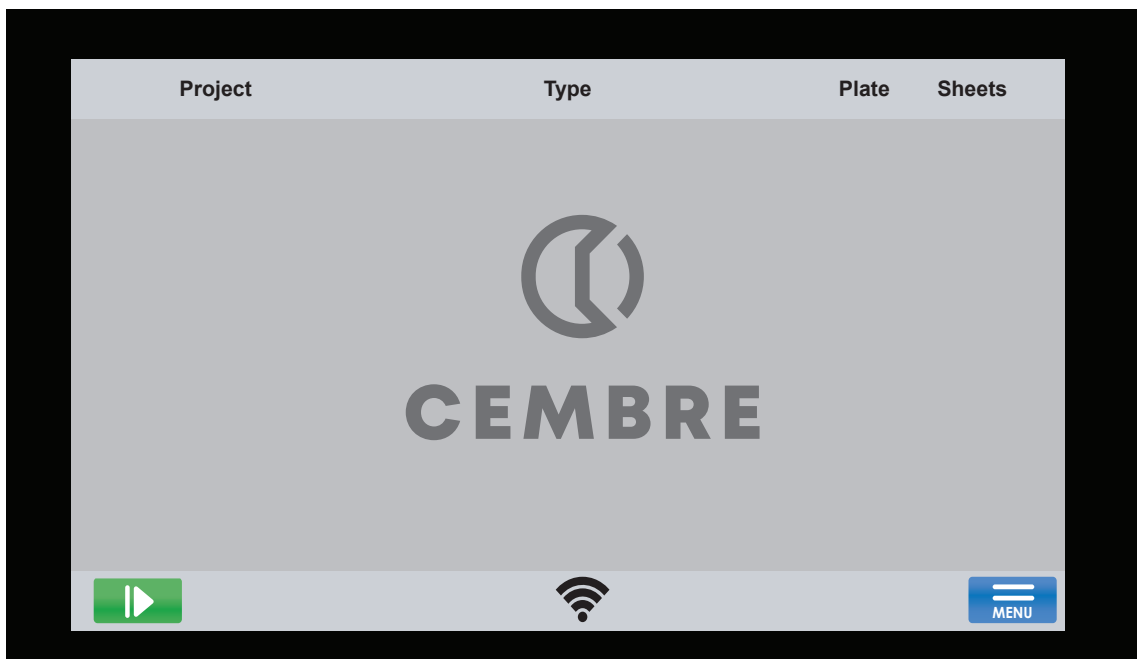

Fig. 6

The touch screen display is operated by lightly tapping with a finger:

- To open a menu or select a menu item, tap the relevant symbol.
- To scroll through the lists, drag your finger upwards or downwards, to the right or left, on the display.
- Main menu symbols:

	Go to internal menu or return to the previous menu.		Confirm your choice
	Stop the print job		Return to the home screen
	Open the tray or continue the print job		Immediate printing
	Exit settings without saving		Close the tray

Table 1 Main symbols

In certain software or hardware configurations, additional symbols appear on the start screen.

The print settings are already configured for correct usage and are protected by the **security PIN: 0000**

main menu

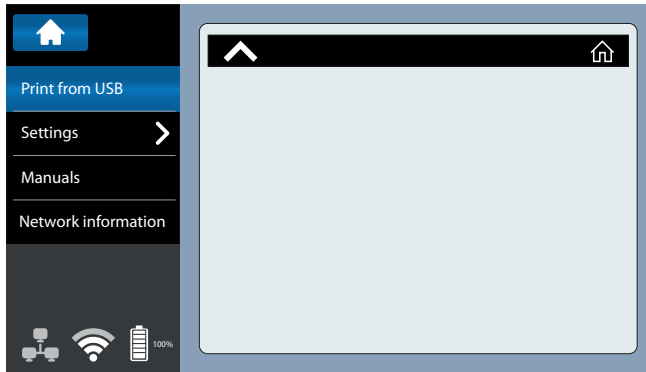
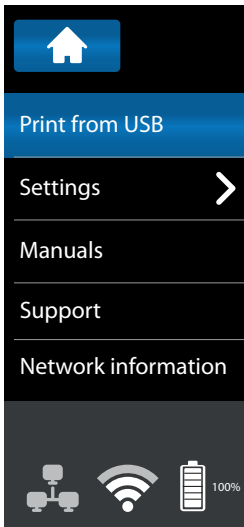

Print a job via USB flash drive inserted into the port (9) at the back of the printer.

refer to page 12

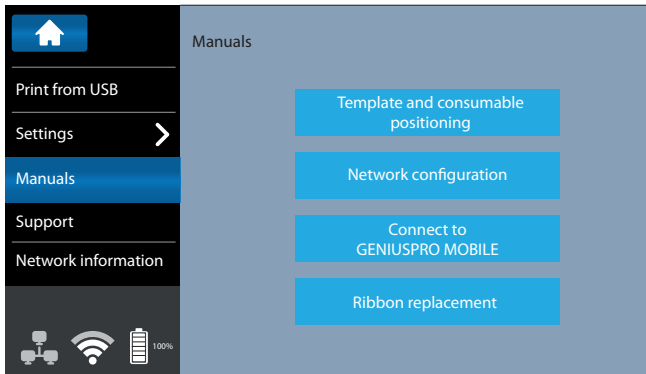

Basic instructions for carrying out the main operations.

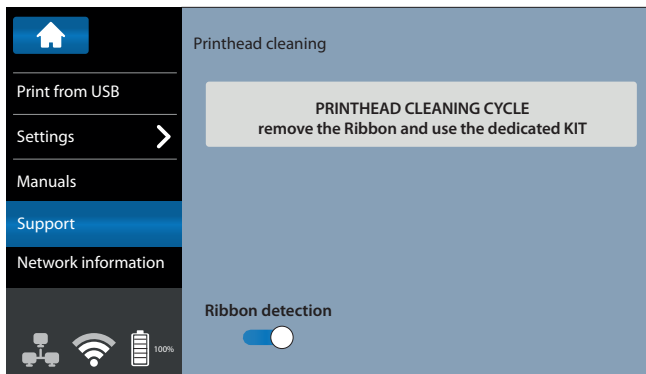

Start phase for printhead cleaning. MG2-CKP CLEANING KIT 991670 is required.

It is advisable to disable "Ribbon detection" when using coloured ribbons.

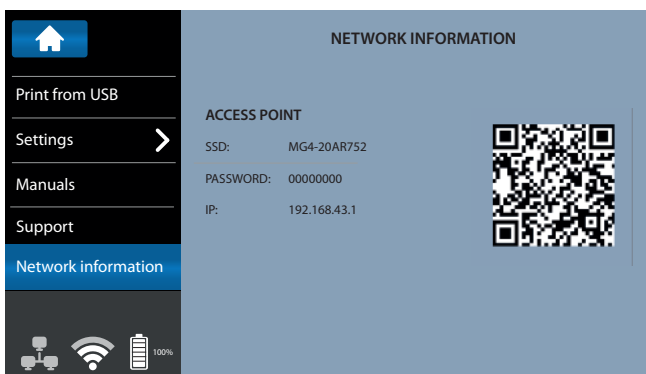

Network settings for Wifi connection or Access Point. QRCode to be scanned to automatically detect the settings.

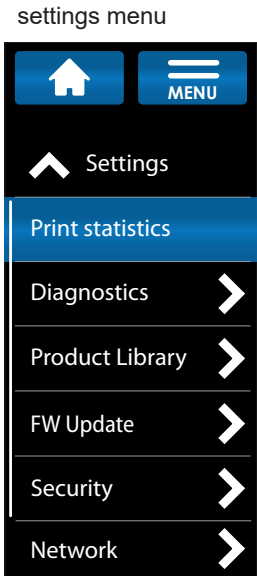

settings menu

refer to page 13

Type	Printed sheets
41090N	27
41390N	23
47091N	10
40092	4

History of print jobs carried out.

Check the print quality:  
- black bands test.  
- alignment test.

Manually load a sheet onto the interface template and press print.

Tray position: Home, Loading

Loading position: Standard

Limit stop: [Slider]

Commands to check the correct operation of the main functions.

Motor: Tray, Printhead position, Ribbon

Position: [Left/Right arrows]

Check the correct movement of the motors  
(press ◀ or ▶ to check movement)

Reset settings

Limit stop	Description	Value
01	PRINTHEAD UP	1
02	TRAY POSITION HOME	1
03	TRAY MOVEMENT	1
04	TOP COVER DETECTION	1
05	SHEET DETECTION	0
06	LOADER IN STOP/RELEASE POSITION	1
07	LOADER IN PRE-SELECTION POSITION	1
08	UNLOADER UP	1
09	UNLOADER LOW	0
10	MANUAL MODE	1
11	LIFTER UP	0
12	LIFTER LOW	1
13	RIBBON DETECTION	1

General overview of printer settings  
0 = false  
1 = true

settings menu



refer to page 14

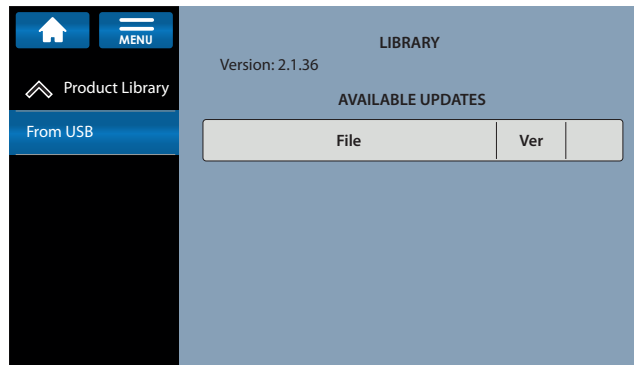

Using a USB flash drive, load the updated library of printable CEMBRE products into the printer (GENIUSPRO Media Library file downloadable from the ASSISTANCE section of [www.cembre.com](http://www.cembre.com))

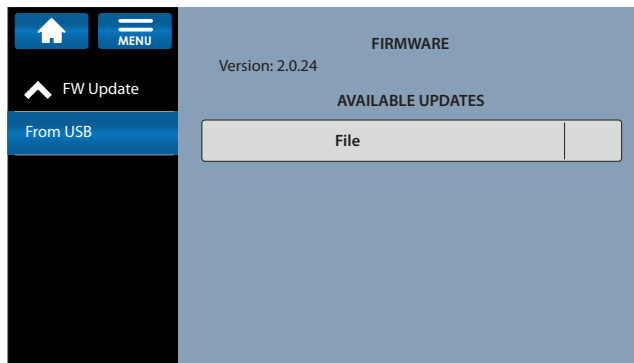

Using a USB flash drive, load a firmware update (downloadable from the ASSISTANCE section of [www.cembre.com](http://www.cembre.com))

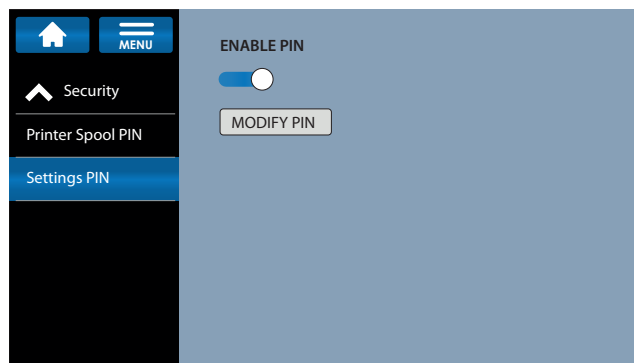

Setting a password to manage the print queue.

Enter a password to manage the menu settings.  
**Default PIN: 0000**

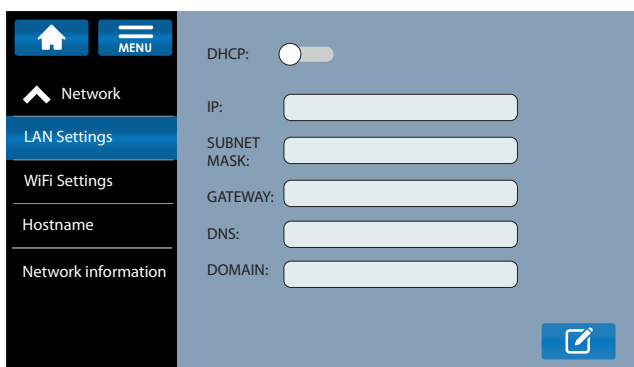

Settings for connecting to the LAN network.

Press to input the requested data or enable the DHCP mode.

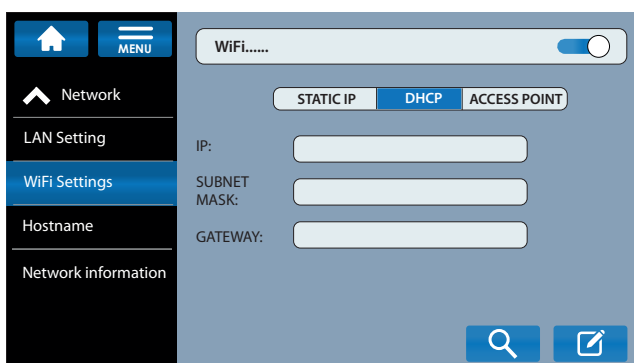

Settings for connecting to the Wi-Fi network or Access point.

Enable the function at the top right  
Press to choose the setting and enter required data  
Press to search and select nearby wireless.

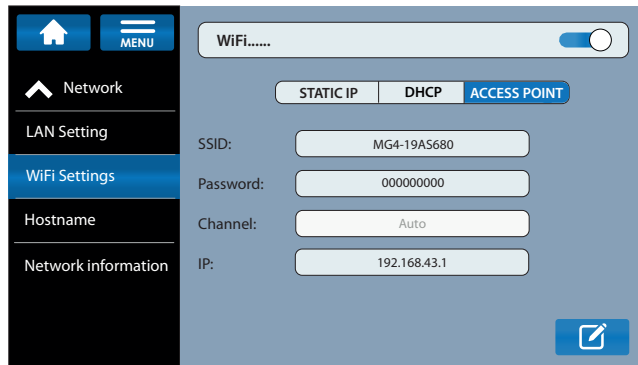
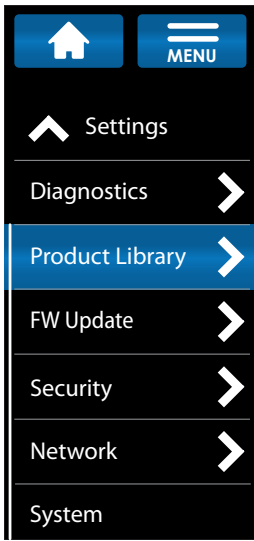

settings menu



Settings for:  
 menu language  
 date / time  
 screen standby (minutes)  
 Timer pin (minutes)  
 work standby.

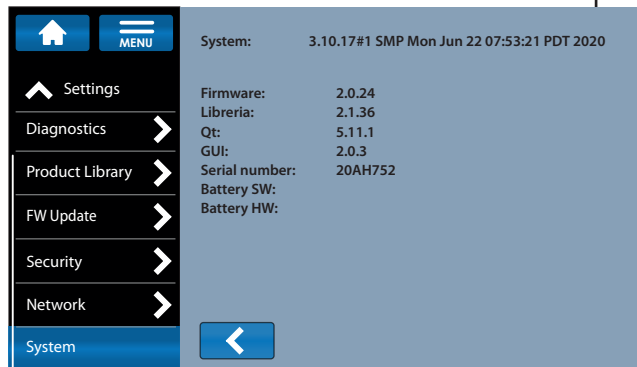

Information on:  
 operating system:  
 firmware version  
 Printer serial number

### 4.1 Positioning the interface template

To keep the print sheets in the correct position on the loading carriage, the latter must be equipped with a special interface template (Fig. 8a):

- ▶ Choose the interface template most suitable for the product to be printed (Ref. to table A).
- ▶ Correctly place the interface template (Fig. 8b) on the mobile carriage so that the two guide pins fit into the corresponding holes under the template.

PRODUCT TO BE MARKED:		Interface template				
		MG2-PLT	MG2-PWC	MG2-QTB	MG2-PTM	MG2-PTD
MG-TPMF	Cable tags for holders	•				
MG-TPM	Cable tags for holders		•			
MG-TDM	Cable tags without holders				•	•
MG-TDMO	Opened Cable tags without holders				•	
MG-ETF	Cable tie-on tags	•				
MG-KMP	Wraparound cable markers	•				
MG-CPM	Terminal marker tags			•		
MG-CPMF	Terminal marker strips	•				
MG-VYB	Terminal marker labels	•				
MG-SPM	Contactors and component markers			•		
MG-TAP	Cable and component legends	•				
MG-PTS	Pushbutton legends	•				
MG-TAPW	Cable and component legends	•				
MG-TAR	Cable and component legends	•				
MG-DOG	Cable and component dog tags	•				
MG-TAA	Adhesive component legends	•				
MG-VYT	Adhesive component labels	•				
MG-VCT	Adhesive component labels	•				
MG-PYT	Adhesive component labels	•				
MG-SAT	Safety labels	•				
MG-PLC	PLC legends	•				
MG-17.5	Modular legends and labels	•				
MG-VRT	Panel plates	•				
MG-SIGNS	Panel legends and labels	•				

Table A

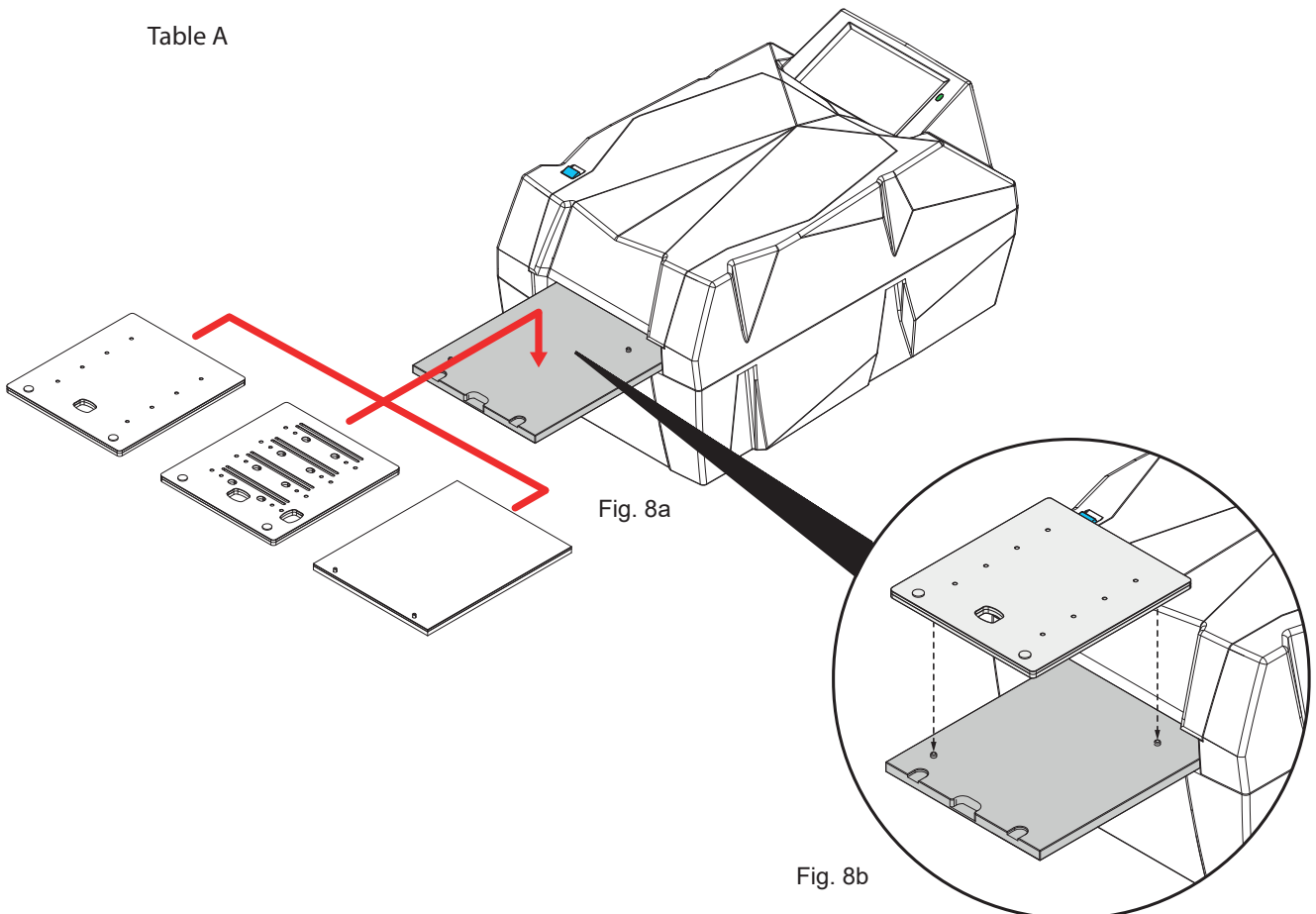

Fig. 8a

Fig. 8b

## 4.2 Changing the print ribbon

To facilitate the unwinding of the ribbon, we recommend retracting the mobile carriage (5);

- ▶ Remove the top lid (3) (Fig. 9a).
- ▶ Rotate the front media guide (15) completely downwards (Fig. 9b).
- ▶ Remove the ribbon take-up spool (13) by releasing it and lifting it up. Then insert the cardboard core (M) included in the supply (Fig. 9c).
- ▶ Pull out the ribbon take-up spool (14) by releasing it and raising it, thread the print ribbon through, aligning the slot with the reference pin on the spindle (Fig. 9c).
- ▶ Unroll the ribbon by passing it under the rear guide (18) (Fig. 9) and then under the print head (20) until it comes out on the opposite side (Fig. 9d).
- ▶ Pull the ribbon further so that it passes over the front guide (19) (Fig. 9).
- ▶ Tape the end of the print ribbon to the cardboard core of the spindle (13). We recommend that you wind the print ribbon tightly around the cardboard core for a few turns in order to achieve correct take-up.
- ▶ Then secure the spool (14) in place by pushing it fully into its seating (Fig. 9d).
- ▶ Lock the ribbon take-up spool (13) in place by pushing it all the way down so that the ribbon is taut (Fig. 9d).
- ▶ Turn the front media guide (15) completely upwards.
- ▶ Replace the upper lid (3).



### Caution!

Ensure that the media guide is rotated fully upwards

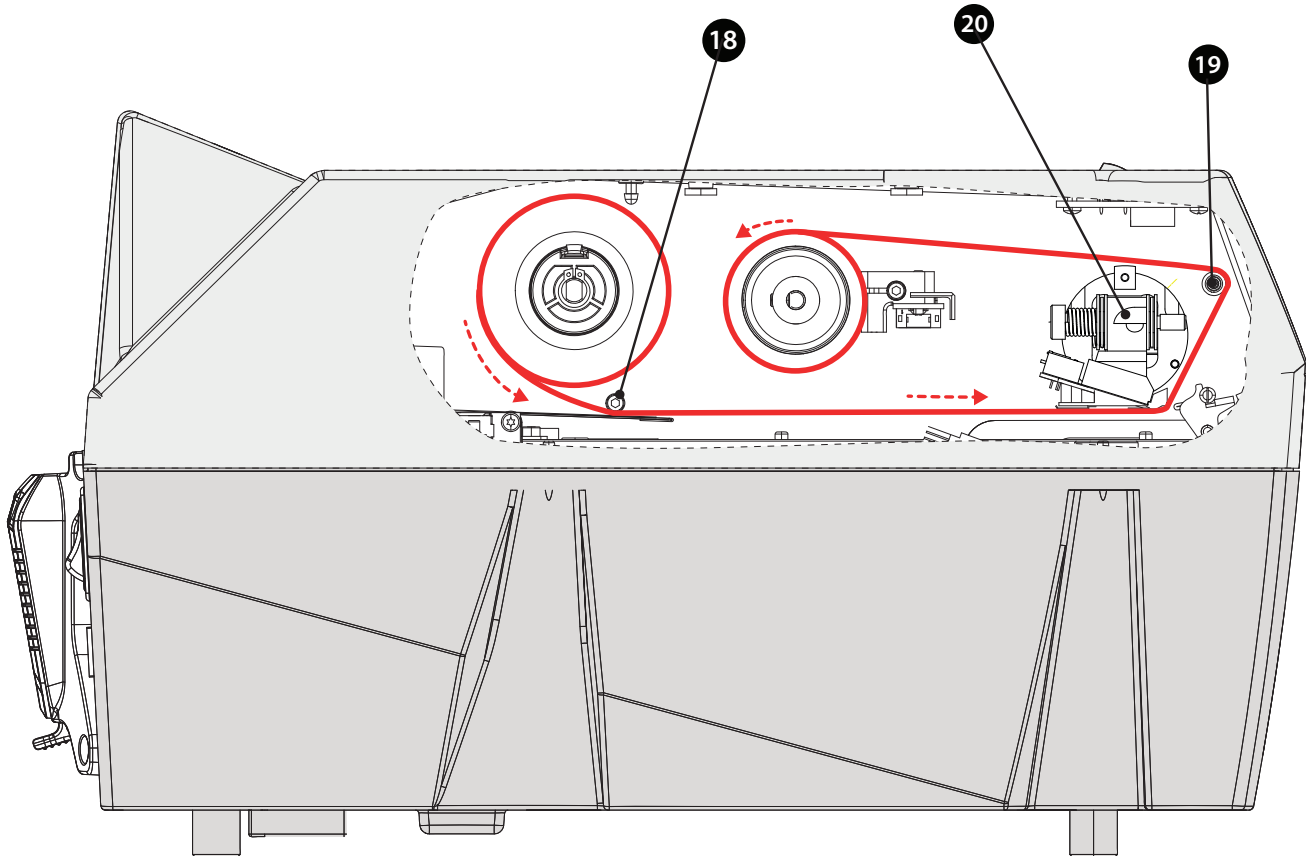

Fig. 9 Print ribbon path



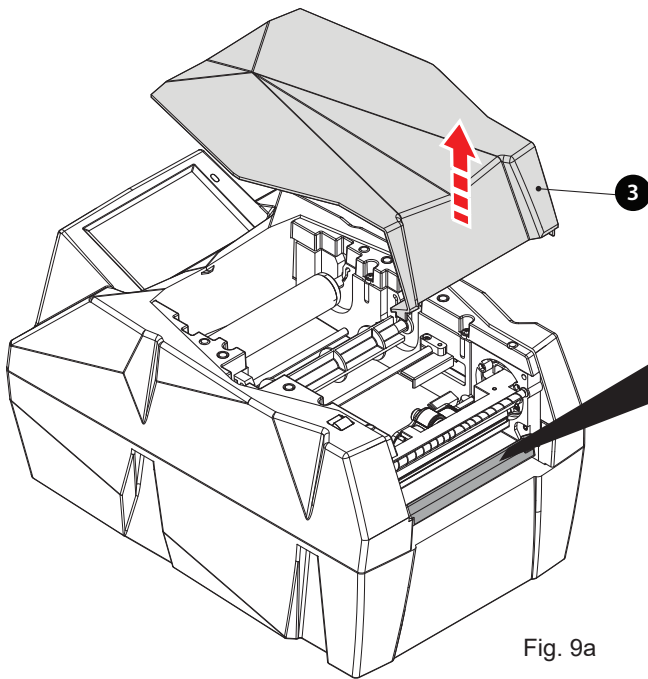

Fig. 9a

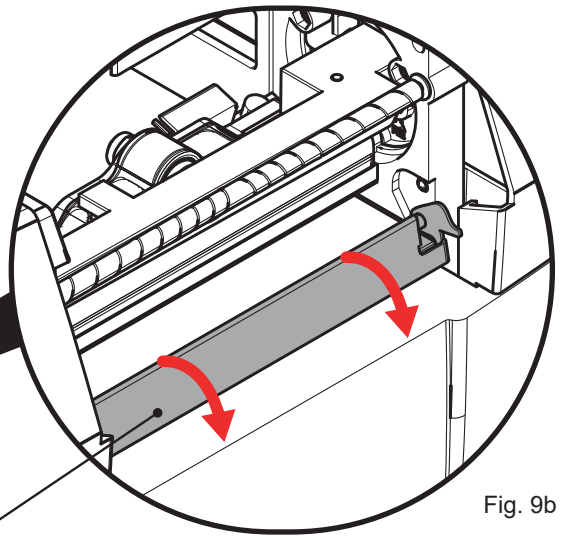

Fig. 9b

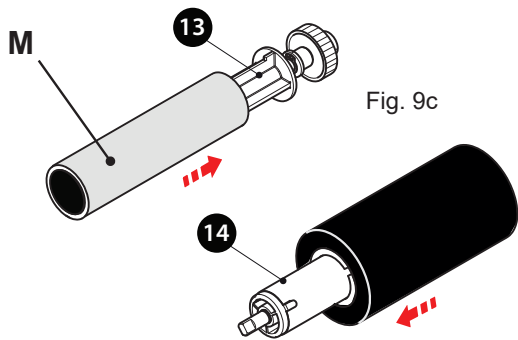

Fig. 9c

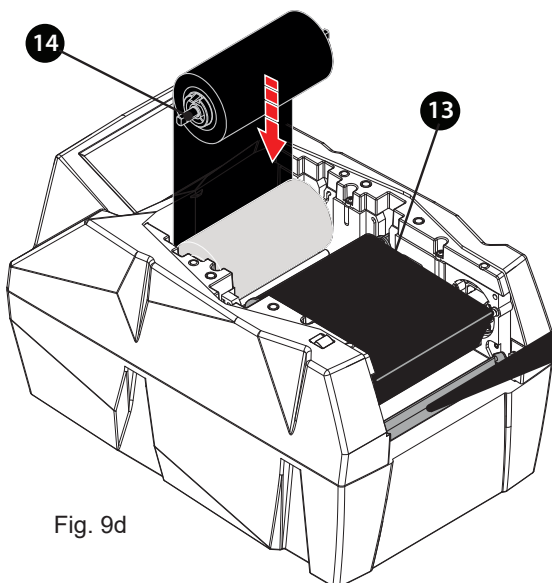
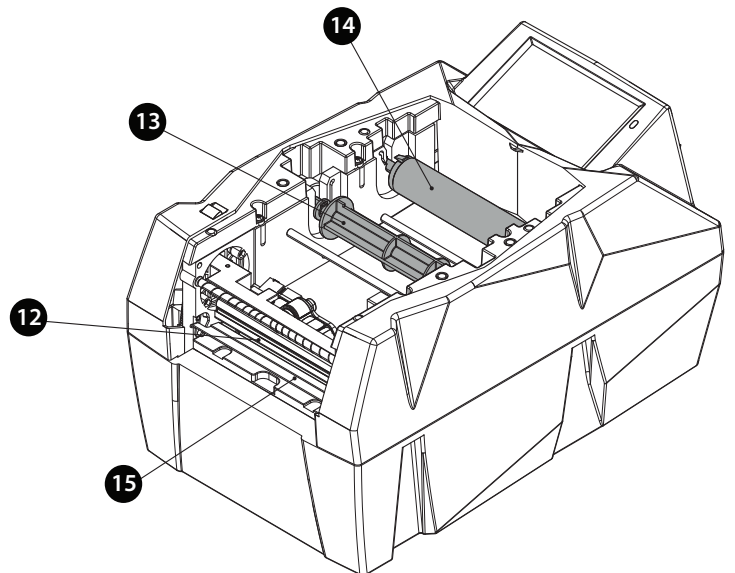
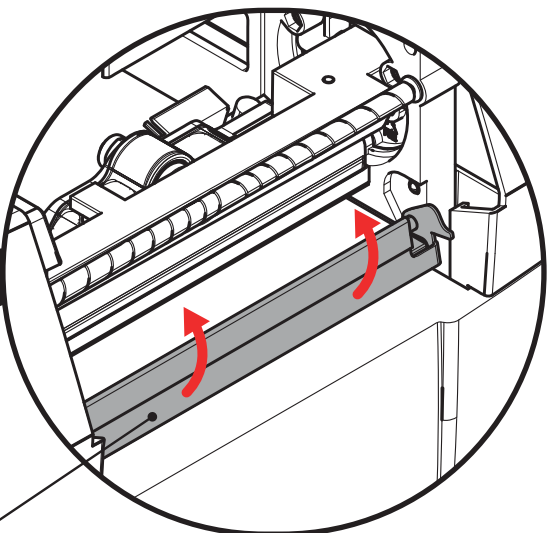

Fig. 9d



15

**Caution!**

- ▶ Keep your hands away from the carriage area during printing.
- ▶ The printer will not start if the guard (3) is not correctly positioned.

**Note!**

To get the best printing results, we recommend following these rules:

- Only use genuine CEMBRE consumables (sheets, print ribbons, etc.).
- Handle the sheets carefully once out of the package and avoid touching the print area with your fingers.
- Before printing, always check that the sheets are free of dirt or residue. If necessary, clean the printing surface with a soft cloth.
- Keep the sheets to be printed inside their packaging in a dry and clean place.
- When printing partially used sheets, make sure that there are no protruding burrs along the length of the sheets along the punching edges or upward facing plates that could damage the print head.
- When printing partially used sheets, make sure that you are using a print file that has been suitably modified for the number of sheets actually present on the sheet; executing a complete print with a partially used sheet could irreparably damage the print head.

## 5.1 Printing process

Manually load a sheet onto the interface template in order to block its movement; the striker feet under the sheet should match the holes in the template and the side stems should be facing the inside of the printer (Fig. 10).

After processing the print job using GENIUSPRO software, start printing.

The printing procedure includes the following phases:

1. The mobile carriage (1) retracts inside the printer.
2. The sheet is printed, then the carriage protrudes (1).
3. Manually remove the printed sheet from the template (Fig. 11).

Then manually detach the markers or tags from the sheet.

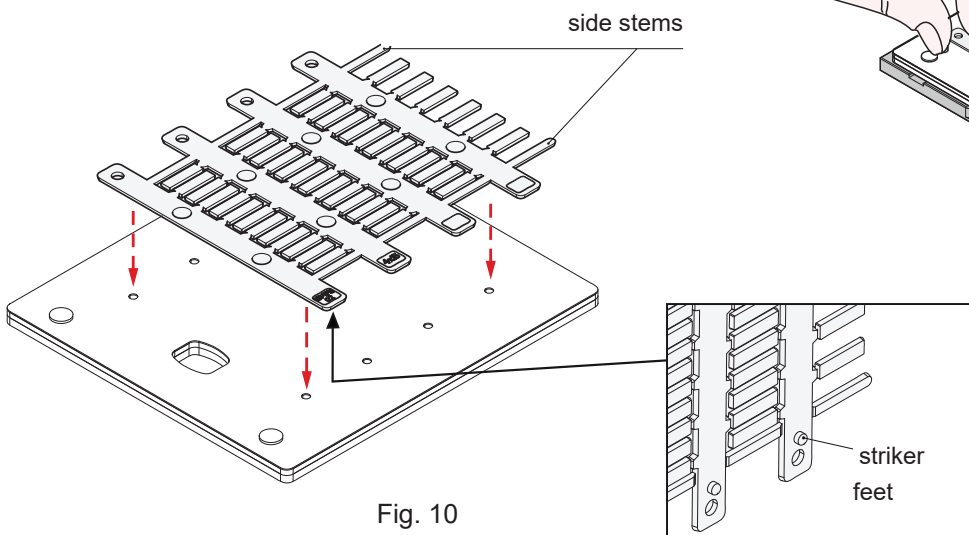

## 6.1 Cleaning instructions



**Danger!**  
Disconnect the printer from the mains before maintenance.

The printer only requires minimal care. However, it is important to regularly clean the thermal print head. This ensures consistently good print quality and plays a major role in preventing premature wear of the print head. For the rest, maintenance is limited to monthly cleaning of the device.



**Caution!**  
Aggressive cleaning products may damage the printer!  
Do not use abrasive products or solvents to clean the external surfaces or the units.

- ▶ Remove dust and print debris in the loader and print area with a soft brush or vacuum cleaner.
- ▶ Clean the external surfaces with a gentle detergent.

## 6.2 Cleaning the print head

How often to clean: after each ribbon spool replacement or as needed.

Dirt can accumulate on the print head during printing, affecting the print quality.



**Caution!**  
Damage to the print head!  
Do not use hard or abrasive objects to clean the print head.  
Do not touch the protective glass layer of the print head.



**Caution!**  
Risk of injury from the heat of the print head.  
Before cleaning, make sure the print head has cooled down.

- ▶ Remove the ribbon from the printer.
- ▶ Clean the print head with a stick or a cotton swab dipped in pure alcohol.
- ▶ Allow the print head to dry for 2-3 minutes.

## 7.1 Inserting/removing the batteries

**Caution!**

- ▶ Use only batteries specified by the Manufacturer Risk of fire or explosion if battery is replaced with an incorrect type.
- ▶ Only charge batteries with the charger specified by the Manufacturer.
- ▶ Protect batteries from water and moisture!
- ▶ Do not expose batteries to fire!
- ▶ Do not open batteries!
- ▶ Do not touch or short-circuit the battery contacts! Keep the battery away from metal objects that can create a connection between the contacts.
- ▶ Do not use defective or deformed batteries.
- ▶ A slightly acidic, flammable liquid may leak from defective lithium batteries. If battery fluid leaks from the battery and comes into contact with the skin, rinse immediately with plenty of water. If battery fluid comes into contact with the eyes, rinse with clean water and seek immediate medical attention.
- ▶ Always recycle batteries at the end of their life.
- ▶ Never dispose of batteries in household waste.
- ▶ They should be taken to the appropriate collection centres for disposal.



- ▶ Switch off the printer and disconnect the power supply.
- ▶ Remove the protective lid (5) of the contacts by pulling the release button (6) upwards (Fig. a).
- ▶ Insert the battery (O) from above by sliding it into the guides until it locks into place (Fig. b).

**Note!**

When you connect the power supply unit with the battery inserted in the printer, the power supply automatically switches to mains.

When the power supply unit is connected and supplied from the mains, it is advisable to remove the battery from the printer and protect the contacts with the lid (5).

The power supply unit does not function as a battery charger! The battery must only be charged using the charger provided by CEMBRE.

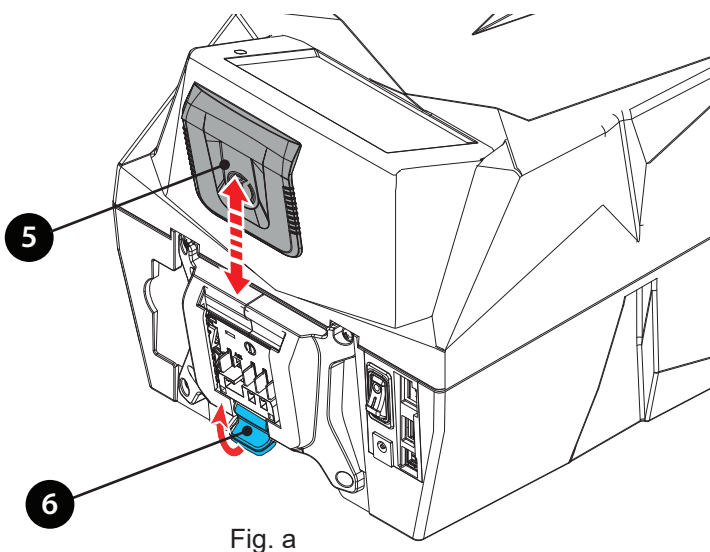

Fig. a

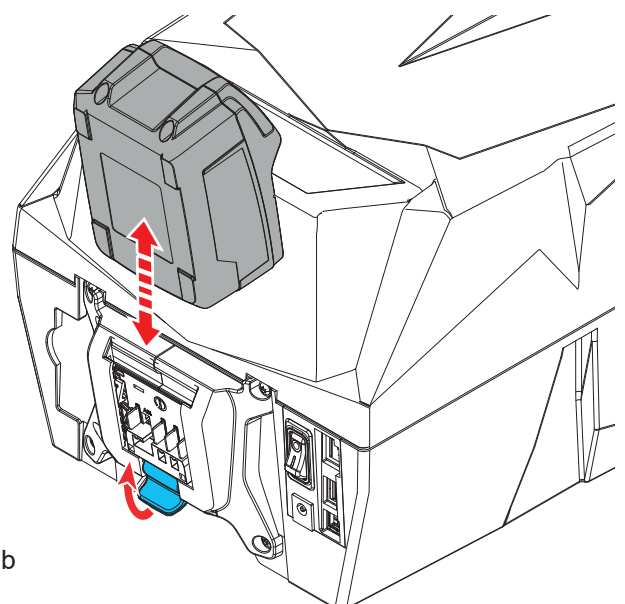

Fig. b

## 7.2 Battery autonomy

- ▶ The battery is equipped with LED indicators to show the remaining amount of charge at any time.

Press button (P):

4 LEDs on: fully charged

2 LEDs on: 50% charged

1 flashing LED: low battery, recharge

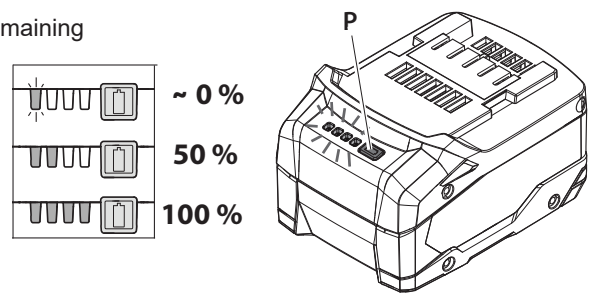

- ▶ The remaining charge can also be checked on the printer display



## 7.3 Using the battery charger

- ▶ Carefully follow the detailed instructions in the relevant user manual.
- ▶ The time for recharging a fully depleted battery (e.g. CB1852L) is approximately 100 min, using the charger type ASC55.

## 8 Environment



In the event of disposal, the appliance contains valuable recyclable materials which can be recovered.

The modular structure of the printer allows complete disassembly.

- ▶ Send the parts for recycling.



The following information concerns the member states of the European Union:

- ▶ **USER INFORMATION in accordance with Directives 2011/65/EU and 2012/19/EU.**

The 'Not in the bin' symbol above when shown on equipment or packaging means that the equipment must, at the end of its life, be disposed of separately from other waste. The separate waste collection of such equipment is organised and managed by the manufacturer. Users wishing to dispose of such equipment must contact the manufacturer and follow the prescribed guidelines for its separate collection. Appropriate waste separation, collection, environmentally compatible treatment and disposal is intended to reduce harmful environmental effects and promote the reuse and recycling of materials contained in the equipment. Unlawful disposal of such equipment will be subject to the application of administrative sanctions provided by current legislation.

## 9 Warranty

**MG4** is guaranteed for one year against existing defects and faults.

The print head is excluded from the warranty as it is considered a consumable material.

The warranty is void if non-original CEMBRE spare parts are used.



**DECLARATION OF CONFORMITY -  
DECLARATION DE CONFORMITE - KONFORMITÄTSEKTLÄRUNG -  
DECLARACIÓN DE CONFORMIDAD - DICHIARAZIONE DI CONFORMITÀ**

We Nous Wir Nos Noi: **CEMBRE S.p.A. Via Serenissima, 9 – 25135 Brescia (Italy)**

Declare under our sole responsibility that the product - *Déclarons sous notre seule responsabilité que le produit*  
- Erklären in alleiniger Verantwortung dass das Produkt - *Declaramos bajo nuestra responsabilidad que el producto*  
- Dichiariamo sotto nostra unica responsabilità che il prodotto:

**MG4 MG4A MGE**

To which this declaration relates is in conformity with the following standard(s) or other normative document(s) -  
*Auquel cette déclaration se réfère est conforme à la (aux) norme(s) ou autre(s) document(s) normatif(s) -*  
Auf dass sich diese Erklärung bezieht, mit der/den folgenden Norm(en) oder dem/den normativen Dokument(en)  
über einstimmt - *Al que se refiere esta declaración, cumple la(s) norma(s) u otro(s) documento(s) normativo(s) -*  
Al quale si riferisce questa dichiarazione è conforme alla(e) norma(e) o altro(i) documento(i) normativo(i):

**EN 62368-1 + A11 + AC EN 55032 + A11 + AC EN 55035 + A11  
EN 61000-3-2 EN 61000-3-3 EN IEC 63000 EN 62311**

Following the provisions of EU directive(s) - *Conformément aux dispositions de(s) directive(s) EU -*  
Gemäß den Bestimmungen der EU Richtlinien - *De acuerdo con las disposiciones de la(s) directiva(s) EU*  
Conformemente alle disposizioni della(e) direttiva(e) EU:

**2014/30/EU 2011/65/EU 2014/35/EU**

Person authorised to compile the technical file - *Personne autorisée à constituer le dossier technique -*  
Person die bevollmächtigt ist, die technischen Unterlagen zusammenzustellen -  
*Persona facultada para elaborar el expediente técnico - Persona autorizzata a costituire il file tecnico:*

**Gianluca Cama via Serenissima, 9 – 25135 Brescia (Italy)**

Brescia **03-01-2022**



Felice Albertazzi  
CHIEF SALES & MARKETING OFFICER  
Cembre S.p.A.



**DECLARATION OF CONFORMITY**

We: **CEMBRE S.p.A. Via Serenissima, 9 – 25135 Brescia (Italy)**

Declare under our sole responsibility that the product:

**MG4 MG4A MGE**

To which this declaration relates is in conformity with the following standard(s) or other normative document(s):

**EN 62368-1 + A11 + AC EN 55032 + A11 + AC EN 55035 + A11  
EN 61000-3-2 EN 61000-3-3 EN IEC 63000 EN 62311**

Following the provisions of the UK Legislation(s):

**S.I. 2016/1091 S.I. 2012/3032 S.I. 2016/1101**

Brescia **03-01-2022**



Felice Albertazzi  
CHIEF SALES & MARKETING OFFICER  
Cembre S.p.A.

- FCC** This equipment has been tested and found to comply with the limits for a Class B digital device, pursuant to part 15 of the FCC Rules.
- These limits are designed to provide reasonable protection against harmful interference in a residential installation. This equipment generates, uses and can radiate radio frequency energy and, if not installed and used in accordance with the instructions, may cause harmful interference to radio communications. However, there is no guarantee that interference will not occur in a specific installation. If this equipment does cause harmful interference to radio or television reception, which can be determined by turning the equipment off and on, the user is encouraged to try to correct the interference by one or more of the following measures:
- Reorient or reposition the receiving antenna.
  - Increase the distance between the equipment and the receiver.
  - Connect the equipment into an outlet on a circuit different from that to which the receiver is connected.
  - Consult the retailer or an experienced radio/TV technician for help.
- Any changes or modifications not expressly approved by the party responsible for compliance may void the user's right to use this equipment.

### **Wireless functionality**

The equipment contains the FCC, IC, ETSI/CE certified wireless module and indicated below:  
manufacturer: Texas Instruments  
type: WL1831MOD  
FCC ID: Z64-WL18SBMOD  
IC: 4511-WL18SBMOD  
MIC certificate number: 201-135370

## **11 Return to CEMBRE for overhaul**

In the case of a breakdown, contact our Area Agent who will advise you on the problem and give you the necessary instructions on how to dispatch the tool to our nearest service Centre; if possible, attach a copy of the Test Certificate supplied by CEMBRE together with the tool or fill in and attach the form available in the "ASSISTANCE" section of the CEMBRE website.



[www.cembre.com](http://www.cembre.com)

**CEMBRE S.p.A.**  
via Serenissima, 9  
25135 Brescia  
Italy  
Ph +39 030 36921  
[ufficio.vendite@cembre.com](mailto:ufficio.vendite@cembre.com)  
[sales@cembre.com](mailto:sales@cembre.com)

**CEMBRE Ltd.**  
Dunton Park,  
Kingsbury Road,  
Curdworth, Sutton Coldfield  
West Midlands, B76 9EB  
United Kingdom  
Ph +44 01675 470440  
[sales@cembre.co.uk](mailto:sales@cembre.co.uk)

**CEMBRE S.a.r.l.**  
22 Avenue Ferdinand  
de Lesseps  
91420 Morangis Cedex  
France  
Ph +33 01 60 49 11 90  
[info@cembre.fr](mailto:info@cembre.fr)

**CEMBRE España S.L.U.**  
Calle Verano 6 y 8  
Pl Las Monjas  
28850 Torrejón de Ardoz  
Madrid - Spain  
Ph +34 91 4852580  
[comercial@cembre.com](mailto:comercial@cembre.com)

**CEMBRE GmbH**  
Geschäftsbereich  
Energie- und Bahntechnik  
Heidemannstr. 166  
80939 München  
Germany  
Ph + 49 89-3580676  
[info@cembre.de](mailto:info@cembre.de)



**CEMBRE GmbH**  
Geschäftsbereich  
Industrie und Handel  
Boschstraße 7  
71384 Weinstadt  
Germany  
Ph +49 7151-20536-60  
[info-w@cembre.de](mailto:info-w@cembre.de)



**CEMBRE Inc.**  
Raritan Center Business Park  
300 Columbus Circle-S.F.,  
Edison, NJ 08837 USA  
Ph +1 (732) 225-7415  
[sales.us@cembre.com](mailto:sales.us@cembre.com)  
Midwest Office  
1051 Perimeter Dr #610  
Schaumburg, IL 60173