

Ring Lug Terminal Block Conectores para Terminal Ojal

The ASIST series of DIN rail mounted terminal blocks is a complete family of modular terminal blocks ranging in size from 1.5mm to 25mm for feed-through wiring. Also included are double level blocks to save space in the panel, multiple connection blocks to reduce wire and terminal block jumpers, fuse blocks and a sliding link block for control transformer and other electrical circuits. The ASIST series is ideal for industries such as electric utilities, switchgear and electrical panel manufacturers and others that require a ring tongue terminal on the wire to insure a secure connection.

The ASIST series of ring lug terminal blocks has more features than competing terminal blocks and are made of higher quality materials, such as UL94V0 polyamide housings. Features include:

- ▶ Housing material rated at UL94V0.
- ▶ Screw accepts both slotted and Phillips head screwdriver.
- ▶ Screw is nickel plated to insure better corrosion protection.
- ▶ Flat and locking washers are standard and provide better contact to terminal and locks terminal in place.
- ▶ Terminal blocks accept a jumper internally for connecting adjacent terminal blocks.
- ▶ Current carrying bar is over 75% bigger than the competition to insure maximum current handling capability.
- ▶ Large marking strips provide easy labeling and they snap onto the blocks in strips of 10 to save time.
- ▶ Double level and multiple connection blocks are available.
- ▶ Fuse blocks are available.
- ▶ Sliding link disconnect blocks are available.

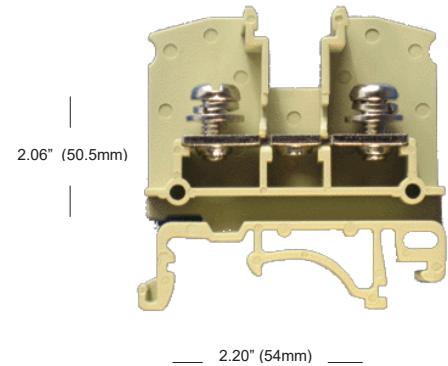

Terminal width .63" (15.5mm)
Terminal espesor

ASIST10

SPECIFICATIONS			WIRE RANGE Sección Transversal	CURRENT (A) Corriente	VOLTAGE (V) Tensión
			20 - 6 AWG	65	600
Screw Size / Rosca			M6		
Tightening Torque / Par de apriete			28.5-32.5 Lb In.		
Ordering Information			CATALOG No.	Pcs/Pkg	
Terminal block, standard			ASI271008	50	
Accessories / Accesorios			CATALOG No.	Pcs/Pkg	
End Cover / Tapa			ASI272003	25	
Circuit bridges, pre-assembled internal bridge Puentes conectores			ASI273010	25	
			ASI273011	25	
			ASI273012	10	
External Bridges / Puentes Externos			ASI274010	25	
			ASI274011	25	
			ASI274012	25	
Marker System, strip of 10 blank markers			ASIUD1B	25	
1-10 Horizontal			ASIUKBJ	10	
1-10 Vertical			PR005	1	
End Stop / Tope Final			PR005-1M	1	
Universal (tool-less) 35mm rail only			ASI305001	1	
Assembly Marker (mounts on End Stop)					
Mounting Rail / Rieles, slotted symmetrical 35mm x 7.5mm – 2 meter 1 meter					
DIN Rail Cutter					
Crimp Tool					
Ring Lugs			RV1.25-6	100	
22-16 AWG			RV2-6	100	
16-14 AWG			RV3.5-6	100	
14-12 AWG			RV5.5-6	100	
12-10 AWG			SVL1.25-6	100	
Red			SVL2-6	100	
Blue			SV3.5-6	100	
Black			SV5.5-6	100	
Yellow					
Fork Lugs					
22-16 AWG					
16-14 AWG					
14-12 AWG					
12-10 AWG					
Red					
Blue					
Black					
Yellow					