

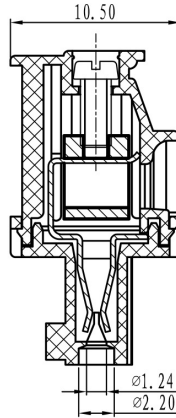

## PCB Terminal Blocks Connector, Left/Top Wire Entry with Screw Lock ASIWJ15EDGKAM-3.5

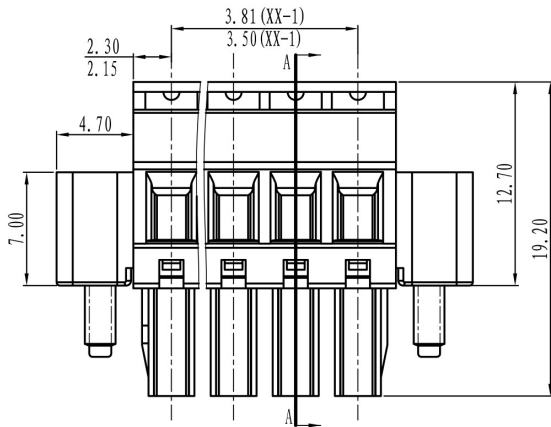

Certification	
	
Material	
Lock Screw	M2.5 Steel, Tin Plated
Screw	M2.0 Steel, Tin Plated
Pin/Plate	Phosphor Bronze, Nickel Plated
Cage	Brass, Nickel Plated
Applicator	Steel, Tin Plated
Housing	PA66, UL 94V-0, Green
Electrical	
Standard	UL 1059/CSA C22.2 No. 158
Rated Voltage	300 V
Rated Current	8 A
Wire Range	28-16 AWG
Contact Resistance	20mΩ
Insulation Resistance	500MΩ/500 Vdc
Withstand Voltage	2000 Vac/1 Min
Mechanical	
Temperature Range	-40°C...+105°C
Torque	0.2N·m (1.8lb·in)
Strip Length	6-7 mm (0.24-0.28")
Size	
Pitch	3.5 mm (.138")
Poles	2P-16P. Additional sizes available on request.

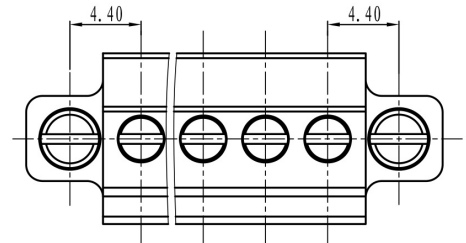

Item	No. of Poles	Length (mm)
ASIWJ15EDGKAM-3.5-2P	2	17.2
ASIWJ15EDGKAM-3.5-3P	3	20.7
ASIWJ15EDGKAM-3.5-4P	4	24.2
ASIWJ15EDGKAM-3.5-5P	5	27.7
ASIWJ15EDGKAM-3.5-6P	6	31.2
ASIWJ15EDGKAM-3.5-7P	7	34.7
ASIWJ15EDGKAM-3.5-8P	8	38.2
ASIWJ15EDGKAM-3.5-9P	9	41.7
ASIWJ15EDGKAM-3.5-10P	10	45.2
ASIWJ15EDGKAM-3.5-11P	11	48.7
ASIWJ15EDGKAM-3.5-12P	12	52.2
ASIWJ15EDGKAM-3.5-13P	13	55.7
ASIWJ15EDGKAM-3.5-14P	14	59.2
ASIWJ15EDGKAM-3.5-15P	15	62.7
ASIWJ15EDGKAM-3.5-16P	16	66.2