

## PCB Terminal Blocks Connector, Front/Top Wire Entry with Screw Clamp Termination ASIWJ2EDGKC-5.0

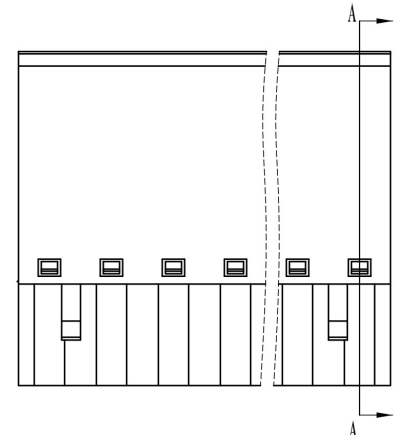
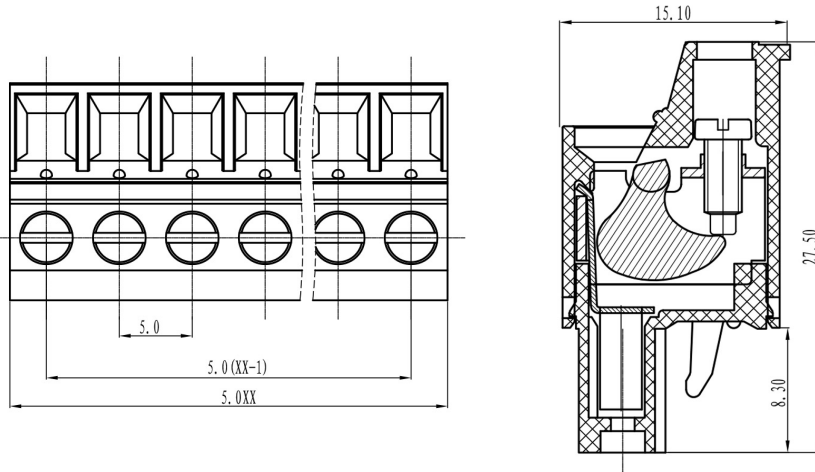

Certification	
Material	
Screw	M2.5 Steel, Tin Plated
Pin/Plate	Phosphor Bronze, Nickel Plated
Cage	Brass, Nickel Plated
Applicator	Steel, Tin Plated
Housing	PA66, UL 94V-0, Green
Electrical	
Standard	UL 1059/CSA C22.2 No. 158
Rated Voltage	300 V
Rated Current	15 A
Wire Range	28-14 AWG
Contact Resistance	20mΩ
Insulation Resistance	500MΩ/500 Vdc
Withstand Voltage	2000 Vac/1 Min
Mechanical	
Temperature Range	-40°C...+105°C
Torque	0.4N-m (3.5lb-in)
Strip Length	7-8 mm (0.28-0.31")
Size	
Pitch	5 mm (.197")
Poles	2P-16P. Additional sizes available on request.

Item	No. of Poles	Length (mm)
ASIWJ2EDGKC-5.0-2P	2	10.0
ASIWJ2EDGKC-5.0-3P	3	15.0
ASIWJ2EDGKC-5.0-4P	4	20.0
ASIWJ2EDGKC-5.0-5P	5	25.0
ASIWJ2EDGKC-5.0-6P	6	30.0
ASIWJ2EDGKC-5.0-7P	7	35.0
ASIWJ2EDGKC-5.0-8P	8	40.0
ASIWJ2EDGKC-5.0-9P	9	45.0
ASIWJ2EDGKC-5.0-10P	10	50.0
ASIWJ2EDGKC-5.0-11P	11	55.0
ASIWJ2EDGKC-5.0-12P	12	60.0
ASIWJ2EDGKC-5.0-13P	13	65.0
ASIWJ2EDGKC-5.0-14P	14	70.0
ASIWJ2EDGKC-5.0-15P	15	75.0
ASIWJ2EDGKC-5.0-16P	16	80.0