

## PCB Terminal Blocks Plug, Screw Lock with Screw Clamp Termination ASIWJ2EDGKM-7.62

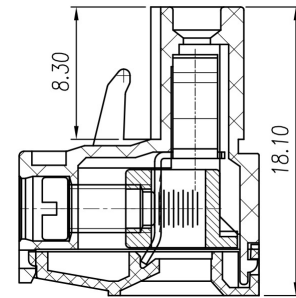
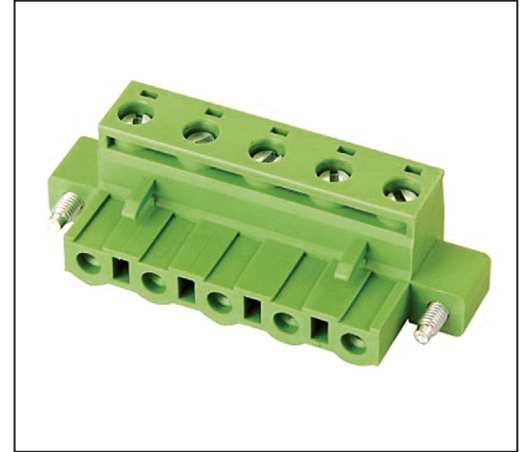
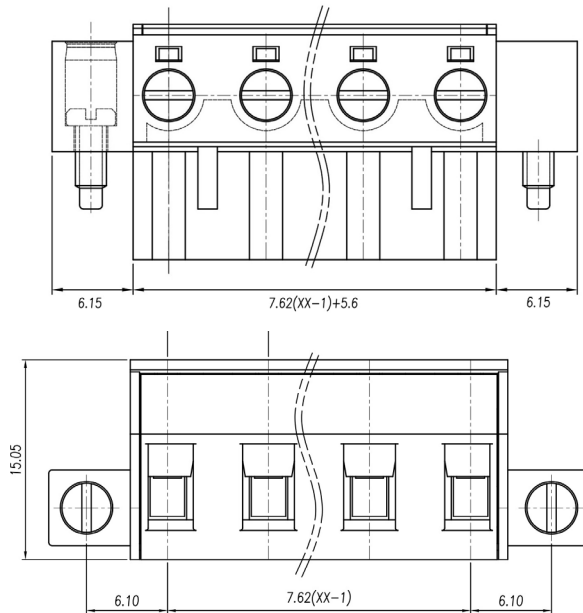

Certification	
Material	
Lock Screw	M2.5 Steel, Tin Plated
Screw	M3.0 Steel, Tin Plated
Pin/Plate	Phosphor Bronze, Nickel Plated
Cage	Copper Alloy, Nickel Plated
Housing	PA66, UL 94V-0, Green
Electrical	
Standard	UL 1059/CSA C22.2 No. 158
Rated Voltage	300 V
Rated Current	15 A
Wire Range	28-14 AWG
Contact Resistance	20mΩ
Insulation Resistance	500MΩ/500 Vdc
Withstand Voltage	2000 Vac/1 Min
Mechanical	
Temperature Range	-40°C...+105°C
Torque	0.5N-m (4.4lb-in)
Strip Length	7-8 mm (0.28-0.31")
Size	
Pitch	7.62 mm (.300")
Poles	2P-12P. Additional sizes available on request.

Item	No. of Poles	Length (mm)
ASIWJ2EDGKM-7.62-2P	2	25.54
ASIWJ2EDGKM-7.62-3P	3	33.16
ASIWJ2EDGKM-7.62-4P	4	40.78
ASIWJ2EDGKM-7.62-5P	5	48.4
ASIWJ2EDGKM-7.62-6P	6	56.02
ASIWJ2EDGKM-7.62-7P	7	63.64
ASIWJ2EDGKM-7.62-8P	8	71.26
ASIWJ2EDGKM-7.62-9P	9	78.88
ASIWJ2EDGKM-7.62-10P	10	86.5
ASIWJ2EDGKM-7.62-11P	11	94.12
ASIWJ2EDGKM-7.62-12P	12	101.74