

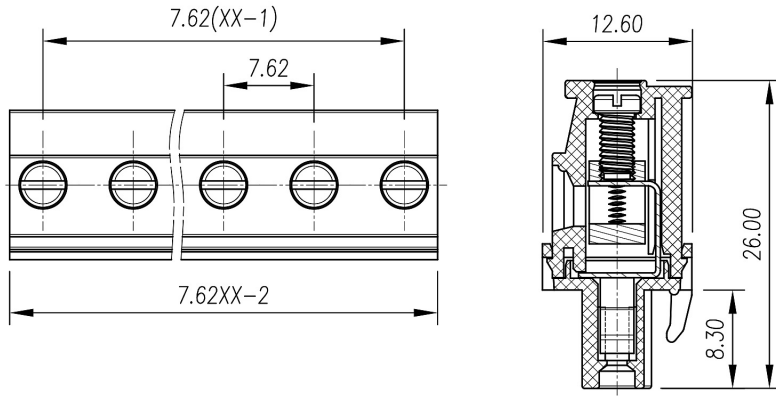

## PCB Terminal Blocks Connector, Right/Bottom Wire Entry with Screw Clamp Termination ASIWJ2EDGKB-7.5



Certification	
	
Material	
Screw	M3.0 Steel, Tin Plated
Pin/Plate	Phosphor Bronze, Nickel Plated
Cage	Copper Alloy, Nickel Plated
Housing	PA66, UL 94V-0, Green
Electrical	
Standard	UL 1059/CSA C22.2 No. 158
Rated Voltage	300 V
Rated Current	15 A
Wire Range	28-14 AWG
Contact Resistance	20mΩ
Insulation Resistance	500MΩ/500 Vdc
Withstand Voltage	2000 Vac/1 Min
Mechanical	
Temperature Range	-40°C...+105°C
Torque	0.5N-m (4.4lb-in)
Strip Length	7-8 mm (0.28-0.31")
Size	
Pitch	7.5 mm (.295")
Poles	2P-16P. Additional sizes available on request.

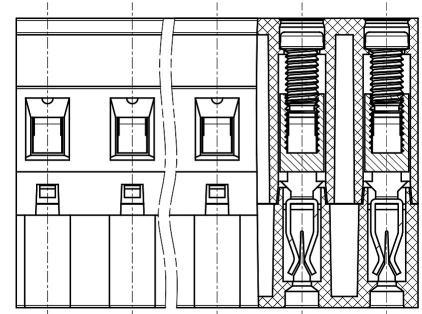

Item	No. of Poles	Length (mm)
ASIWJ2EDGKB-7.5-2P	2	13
ASIWJ2EDGKB-7.5-3P	3	20.5
ASIWJ2EDGKB-7.5-4P	4	28
ASIWJ2EDGKB-7.5-5P	5	35.5
ASIWJ2EDGKB-7.5-6P	6	43
ASIWJ2EDGKB-7.5-7P	7	50.5
ASIWJ2EDGKB-7.5-8P	8	58
ASIWJ2EDGKB-7.5-9P	9	65.5
ASIWJ2EDGKB-7.5-10P	10	73
ASIWJ2EDGKB-7.5-11P	11	80.5
ASIWJ2EDGKB-7.5-12P	12	88